

(12) INTERNATIONAL APPLICATION PUBLISHED UNDER THE PATENT COOPERATION TREATY (PCT)

(19) World Intellectual Property
Organization
International Bureau



(43) International Publication Date
22 July 2004 (22.07.2004)

PCT

(10) International Publication Number
WO 2004/060446 A2

- (51) International Patent Classification⁷: A61M
- (21) International Application Number: PCT/US2003/041702
- (22) International Filing Date: 30 December 2003 (30.12.2003)
- (25) Filing Language: English
- (26) Publication Language: English
- (30) Priority Data:
- | | | |
|------------|-------------------------------|----|
| 60/437,184 | 30 December 2002 (30.12.2002) | US |
| 60/437,185 | 30 December 2002 (30.12.2002) | US |
| 60/437,186 | 30 December 2002 (30.12.2002) | US |
| 60/437,191 | 30 December 2002 (30.12.2002) | US |
| 60/437,192 | 30 December 2002 (30.12.2002) | US |
| 60/437,312 | 30 December 2002 (30.12.2002) | US |
| 60/437,333 | 30 December 2002 (30.12.2002) | US |
| 60/437,334 | 30 December 2002 (30.12.2002) | US |
| 60/437,335 | 30 December 2002 (30.12.2002) | US |
| 60/437,336 | 30 December 2002 (30.12.2002) | US |
| 60/437,337 | 30 December 2002 (30.12.2002) | US |
| 60/437,340 | 30 December 2002 (30.12.2002) | US |
| 60/437,341 | 30 December 2002 (30.12.2002) | US |
| 60/437,342 | 30 December 2002 (30.12.2002) | US |
| 60/437,343 | 30 December 2002 (30.12.2002) | US |
| 60/437,345 | 30 December 2002 (30.12.2002) | US |
| 60/437,346 | 30 December 2002 (30.12.2002) | US |
| 60/437,347 | 30 December 2002 (30.12.2002) | US |
| 60/437,386 | 30 December 2002 (30.12.2002) | US |
| 60/437,454 | 30 December 2002 (30.12.2002) | US |
| 60/437,455 | 30 December 2002 (30.12.2002) | US |
| 60/437,510 | 30 December 2002 (30.12.2002) | US |
| 60/437,514 | 30 December 2002 (30.12.2002) | US |
| 60/437,323 | 31 December 2002 (31.12.2002) | US |
- (71) Applicant (for all designated States except US): PE-
LIKAN TECHNOLOGIES, INC. [US/US]; 1072 East
Meadow Circle, Palo Alto, CA 94303 (US).
- (72) Inventors; and
- (75) Inventors/Applicants (for US only): FREEMAN, Do-
minique, M. [GB/US]; 4545 La Honda Road, La Honda,
CA 94020 (US). BOECKER, Dirk [DE/US]; 1652
Castilleja Avenue, Palo Alto, CA 94306 (US). JONES,
Robert [GB/GB]; Science Park, Milton Road, Cambridge,
CB4 0DW (GB). CULLEN, David [GB/GB]; Silsoe,
Bedfordshire MK45 4DT (GB). MCLEOD, Malcolm
[GB/GB]; Trumpington Street, Cambridge, CB2 1PZ
(GB). CARLSEN, William [US/US]; 540 Weddell Drive,
Suite 1, Sunnyvale, CA 94089 (US). OWEN, Michael, J.
[US/US]; 1505 West Saint Andrews Road, Midland, MI
48640 (US). DRYER, Christopher [US/US]; 1072 East
Meadow Circle, Palo Alto, CA 94303 (US).
- (74) Agent: TUNG, Hao, Y.; Heller, Ehrman White &
McAuliffe LLP, 275 Middlefield Road, Menlo Park, CA
94025-3506 (US).
- (81) Designated States (national): AE, AG, AL, AM, AT (uti-
lity model), AT, AU, AZ, BA, BB, BG, BR, BW, BY, BZ,
CA, CH, CN, CO, CR, CU, CZ (utility model), CZ, DE
(utility model), DE, DK (utility model), DK, DM, DZ, EC,
EE (utility model), EE, EG, ES, FI (utility model), FI, GB,
GD, GE, GH, GM, HR, HU, ID, IL, IN, IS, JP, KE, KG,
KP, KR, KZ, LC, LK, LR, LS, LT, LU, LV, MA, MD, MG,
MK, MN, MW, MX, MZ, NI, NO, NZ, OM, PG, PH, PL,
PT, RO, RU, SC, SD, SE, SG, SK (utility model), SK, SL,
SY, TJ, TM, TN, TR, TT, TZ, UA, UG, US, UZ, VC, VN,
YU, ZA, ZM, ZW.
- (84) Designated States (regional): ARIPO patent (BW, GH,
GM, KE, LS, MW, MZ, SD, SL, SZ, TZ, UG, ZM, ZW),

[Continued on next page]



WO 2004/060446 A2

(54) Title: METHOD AND APPARATUS USING OPTICAL TECHNIQUES TO MEASURE ANALYTE LEVELS

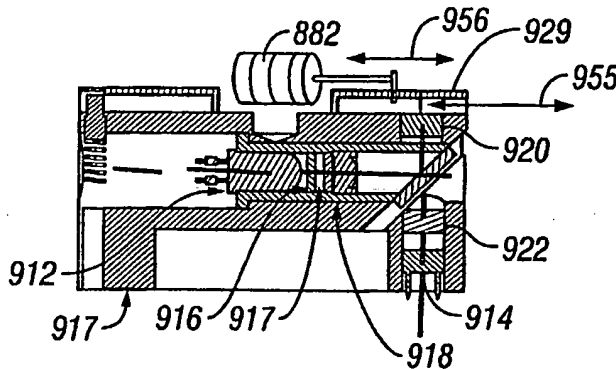

(57) Abstract: A device is provided for use with a tissue penetrating system and/or a metering device for measuring analyte levels. The device comprises a cartridge and a plurality of analyte detecting members mounted on the cartridge. The cartridge may have a radial disc shape. The cartridge may also be sized to fit within the metering device. The analyte detecting members may be optical system using fluorescence lifetime to determine analyte levels. In one embodiment, the device may also include a fluid spreader positioned over at least a portion of the analyte detecting member to urge fluid toward one of the detecting members. A plurality of analyte detecting members may be used. Each analyte detecting member may be a low volume device.



Eurasian patent (AM, AZ, BY, KG, KZ, MD, RU, TJ, TM),
European patent (AT, BE, BG, CH, CY, CZ, DE, DK, EE,
ES, FI, FR, GB, GR, HU, IE, IT, LU, MC, NL, PT, RO, SE,
SI, SK, TR), OAPI patent (BF, BJ, CF, CG, CI, CM, GA,
GN, GQ, GW, ML, MR, NE, SN, TD, TG).

For two-letter codes and other abbreviations, refer to the "Guidance Notes on Codes and Abbreviations" appearing at the beginning of each regular issue of the PCT Gazette.

Published:

— *without international search report and to be republished upon receipt of that report*

METHOD AND APPARATUS USING OPTICAL TECHNIQUES TO MEASURE ANALYTE LEVELS

5

BACKGROUND OF THE INVENTION

Lancing devices are known in the medical health-care products industry for piercing the skin to produce blood for analysis. Typically, a drop of blood for this type of analysis is obtained by making a small incision in the fingertip, creating a small wound, which generates a small blood droplet on the surface of the skin.

Early methods of lancing included piercing or slicing the skin with a needle or razor. Current methods utilize lancing devices that contain a multitude of spring, cam and mass actuators to drive the lancet. These include cantilever springs, diaphragms, coil springs, as well as gravity plumbs used to drive the lancet. The device may be held against the skin and mechanically triggered to ballistically launch the lancet. Unfortunately, the pain associated with each lancing event using known technology discourages patients from testing. In addition to vibratory stimulation of the skin as the driver impacts the end of a launcher stop, known spring based devices have the possibility of firing lancets that harmonically oscillate against the patient tissue, causing multiple strikes due to recoil. This recoil and multiple strikes of the lancet is one major impediment to patient compliance with a structured glucose monitoring regime.

Another impediment to patient compliance is the lack of spontaneous blood flow generated by known lancing technology. In addition to the pain as discussed above, a patient may need more than one lancing event to obtain a blood sample since spontaneous blood generation is unreliable using known lancing technology. Thus the pain is multiplied by the number of attempts required by a patient to successfully generate spontaneous blood flow. Different skin thickness may yield different results in terms of pain perception, blood yield and success rate of obtaining blood between different users of the lancing device. Known devices poorly account for these skin thickness variations.

A still further impediment to improved compliance with glucose monitoring are the many steps and inconvenience associated with each lancing event. Many diabetic patients that are insulin dependent may need to self-test for blood glucose levels five to

six times daily. The large number of steps required in traditional methods of glucose testing, ranging from lancing, to milking of blood, applying blood to a test strip, and getting the measurements from the test strip, discourages many diabetic patients from testing their blood glucose levels as often as recommended. Older patients and those with deteriorating motor skills encounter difficulty loading lancets into launcher devices, transferring blood onto a test strip, or inserting thin test strips into slots on glucose measurement meters. Additionally, the wound channel left on the patient by known systems may also be of a size that discourages those who are active with their hands or who are worried about healing of those wound channels from testing their glucose levels. Still further, the inconvenience of having to carry around a large number of individual test strips encumbers the users of conventional test equipment.

SUMMARY OF THE INVENTION

The present invention provides solutions for at least some of the drawbacks discussed above. Specifically, some embodiments of the present invention provide a multiple lancet solution to measuring analyte levels in the body. The invention may use a high density design, with regards to the number of penetrating members in a cartridge or number of analyte detecting members on a cartridge. The present invention may provide optical techniques for measuring analyte levels. The present invention may provide manufacturing techniques for such optical analyte detecting members. At least some of these and other objectives described herein will be met by embodiments of the present invention.

In one embodiment, a device is provided for use with a metering device or tissue penetrating device for measuring analyte levels. The device comprises a cartridge and a plurality of analyte detecting members mounted on the cartridge. The cartridge may have a radial disc shape. The cartridge may also be sized to fit within the metering device. The analyte detecting members may be optical system using fluorescence lifetime to determine analyte levels. In one embodiment, the device may also include a fluid spreader positioned over at least a portion of the analyte detecting member to urge fluid toward one of the detecting members. A plurality of analyte detecting members may be used. Each analyte detecting member may be a low volume device.

A further understanding of the nature and advantages of the invention will become apparent by reference to the remaining portions of the specification and drawings.

BRIEF DESCRIPTION OF THE DRAWINGS

Figure 1 is a perspective view illustrating a system, according to an embodiment for use in piercing skin to obtain a blood sample;

5 Figure 2 is a plan view of a portion of a replaceable penetrating member cartridge forming part of the system;

 Figure 3 is a cross-sectional end view on 3-3 in Figure 2;

 Figure 4 is a cross-sectional end view on 4-4 in Figure 2;

 Figure 5 is a perspective view of an apparatus forming part of the system and used
10 for manipulating components of the cartridge, illustrating pivoting of a penetrating member accelerator in a downward direction;

 Figure 6A is a view similar to Figure 5, illustrating how the cartridge is rotated or advanced;

 Figure 6B is a cross-sectional side view illustrating how the penetrating member
15 accelerator allows for the cartridge to be advanced;

 Figure 7A and 7B are views similar to Figures 6A and 6B, respectively, illustrating pivoting of the penetrating member accelerator in an opposite direction to engage with a select one of the penetrating members in the cartridge;

 Figures 8A and 8B are views similar to Figures 7A and 7B, respectively,
20 illustrating how the penetrating member accelerator moves the selected penetrating member to pierce skin;

 Figures 9A and 9B are views similar to Figures 8A and 8B, respectively, illustrating how the penetrating member accelerator returns the penetrating member to its original position;

25 Figure 10 is a block diagram illustrating functional components of the apparatus;
 and

 Figure 11 is an end view illustrating a cartridge according to an optional embodiment that allows for better adhesion of sterilization barriers.

 Figure 12 is a cross-sectional view of an embodiment having features of the
30 invention.

 Figure 13 is a cross-sectional view of an embodiment having features of the invention in operation.

Figure 14 is a cross-sectional view illustrating a low-friction coating applied to one penetrating member contact surface.

Figure 15 is a cross-sectional view illustrating a coating applied to one penetrating member contact surface which increases friction and improves the microscopic contact area between the penetrating member and the penetrating member contact surface.

Figure 16 illustrates a portion of a penetrating member cartridge having an annular configuration with a plurality of radially oriented penetrating member slots and a distal edge of a drive member disposed in one of the penetrating member slots.

Figure 17 is an elevational view in partial longitudinal section of a coated penetrating member in contact with a coated penetrating member contact surface.

Figure 18 illustrates an embodiment of a lancing device having features of the invention.

Figure 19 is a perspective view of a portion of a penetrating member cartridge base plate having a plurality of penetrating member slots and drive member guide slots disposed radially inward of and aligned with the penetrating member slots.

Figures 20-22 illustrate a penetrating member cartridge in section, a drive member, a penetrating member and the tip of a patient's finger during three sequential phases of a lancing cycle.

Figure 23 illustrates an embodiment of a penetrating member cartridge having features of the invention.

Figure 24 is an exploded view of a portion of the penetrating member cartridge of Figure 12.

Figures 25 and 26 illustrate a multiple layer sterility barrier disposed over a penetrating member slot being penetrated by the distal end of a penetrating member during a lancing cycle.

Figures 27 and 28 illustrate an embodiment of a drive member coupled to a driver wherein the drive member includes a cutting member having a sharpened edge which is configured to cut through a sterility barrier of a penetrating member slot during a lancing cycle in order for the drive member to make contact with the penetrating member.

Figures 29 and 30 illustrate an embodiment of a penetrating member slot in longitudinal section having a ramped portion disposed at a distal end of the penetrating member slot and a drive member with a cutting edge at a distal end thereof for cutting through a sterility barrier during a lancing cycle.

Figures 31-34 illustrate drive member slots in a penetrating member cartridge wherein at least a portion of the drive member slots have a tapered opening which is larger in transverse dimension at the top of the drive member slot than at the bottom of the drive member slot.

5 Figures 35-37 illustrate an embodiment of a penetrating member cartridge and penetrating member drive member wherein the penetrating member drive member has a contoured jaws configured to grip a penetrating member shaft.

 Figures 38 and 39 show a portion of a lancing device having a lid that can be opened to expose a penetrating member cartridge cavity for removal of a used penetrating member cartridge and insertion of a new penetrating member cartridge.

10 Figures 40 and 41 illustrate a penetrating member cartridge that has penetrating member slots on both sides.

 Figures 42-44 illustrate end and perspective views of a penetrating member cartridge having a plurality of penetrating member slots formed from a corrugated surface of the penetrating member cartridge.

15 Figures 45-48 illustrate embodiments of a penetrating member and drive member wherein the penetrating member has a slotted shaft and the drive member has a protuberance configured to mate with the slot in the penetrating member shaft.

 Figure 49 is a perspective view of a cartridge according to the present invention.

20 Figures 50 and 51 show close-ups of outer peripheries various cartridges.

 Figure 52 is a perspective view of an underside of a cartridge.

 Figure 53A shows a top down view of a cartridge and the punch and pusher devices.

 Figure 53B is a perspective view of one embodiment of a punch plate.

25 Figures 54A-54G show a sequence of motion for the punch plate, the cartridge, and the cartridge pusher.

 Figures 55A-55B show cross-sections of the system according to the present invention.

30 Figure 56A shows a perspective view of the system according to the present invention.

 Figures 56B-56D are cut-away views showing mechanisms within the present invention.

 Figures 57-65B show optional embodiments according to the present invention.

Figure 66-68 shows a still further embodiment of a cartridge according to the present invention.

Figures 69A-69L show the sequence of motions associated with an optional embodiment of a cartridge according to the present invention.

5 Figure 70-72 show views of a sample modules used with still further embodiments of a cartridge according to the present invention.

Figure 73 shows a cartridge with a sterility barrier and an analyte detecting member layer.

10 Figure 74-78 show still further embodiments of analyte detecting members coupled to a cartridge.

Figures 79-84 show optional configurations for a cartridge for use with the present invention.

Figure 85 shows a see-through view of one embodiment of a system according to the present invention.

15 Figure 86 is a schematic of an optional embodiment of a system according to the present invention.

Figures 87A-87B show still further embodiments of cartridges according to the present invention.

Figure 88 shows a cartridge having an array of analyte detecting members.

20 Figures 89-90 show embodiments of illumination systems for use with the present invention.

Figures 91-96 show further embodiments using optical methods for analyte detection.

Figure 97 shows a perspective view of one embodiment of the present invention.

25 Figure 98 shows one embodiment of optics according to the present invention.

Figure 99 shows one embodiment of pixel and storage configurations.

Figure 100 is a graph showing fluorescence lifetime intensity.

Figures 101 through 104 show various embodiments of optics according to the present invention.

30 Figure 105 shows one embodiment of a well with microbeads.

Figure 106 through 107B show various configurations of wells and channels.

Figure 108 and 109 show configurations of penetrating members and wells.

Figure 110 shows a still further configuration of optics according to the present invention.

Figure 111 shows a disc-shaped cartridge with wells and attachable separators.

Figure 112 shows a disc-shaped cartridge with a plurality of wells.

5 Figures 113-116 show methods for manufacturing cartridges with wells.

Figure 117 shows one embodiment of the present invention using a separate cartridge for penetrating members and analyte detecting members.

10

DESCRIPTION OF THE SPECIFIC EMBODIMENTS

The present invention provides a multiple analyte detecting member solution for body fluid sampling. Specifically, some embodiments of the present invention provide a multiple analyte detecting member and multiple lancet solution to measuring analyte levels in the body. The invention may use a high density design. It may use lancets of smaller size, such as but not limited to diameter or length, than known lancets. The device may be used for multiple lancing events without having to remove a disposable from the device. The invention may provide improved sensing capabilities. At least some of these and other objectives described herein will be met by embodiments of the present invention.

20

It is to be understood that both the foregoing general description and the following detailed description are exemplary and explanatory only and are not restrictive of the invention, as claimed. It may be noted that, as used in the specification and the appended claims, the singular forms "a", "an" and "the" include plural referents unless the context clearly dictates otherwise. Thus, for example, reference to "a material" may include mixtures of materials, reference to "a chamber" may include multiple chambers, and the like. References cited herein are hereby incorporated by reference in their entirety, except to the extent that they conflict with teachings explicitly set forth in this specification.

25

In this specification and in the claims which follow, reference will be made to a number of terms which shall be defined to have the following meanings:

30

"Optional" or "optionally" means that the subsequently described circumstance may or may not occur, so that the description includes instances where the circumstance occurs and instances where it does not. For example, if a device optionally contains a feature for analyzing a blood sample, this means that the analysis feature may or may not

be present, and, thus, the description includes structures wherein a device possesses the analysis feature and structures wherein the analysis feature is not present.

“Analyte detecting member” refers to any use, singly or in combination, of chemical test reagents and methods, electrical test circuits and methods, physical test components and methods, optical test components and methods, and biological test reagents and methods to yield information about a blood sample. Some of these methods are well known in the art and may be based on teachings of, e.g. Tietz Textbook of Clinical Chemistry, 3d Ed., Sec. V, pp. 776-78 (Burtis & Ashwood, Eds., W.B. Saunders Company, Philadelphia, 1999); U.S. Pat. No. 5,997,817 to Chrismore et al. (Dec. 7, 1999); U.S. Pat. No. 5,059,394 to Phillips et al. (Oct. 22, 1991); U.S. Pat. No. 5,001,054 to Wagner et al. (Mar. 19, 1991); and U.S. Pat. No. 4,392,933 to Nakamura et al. (July 12, 1983), the teachings of which are hereby incorporated by reference, as well as others. Analyte detecting member may include tests in the sample test chamber that test electrochemical properties of the blood, or they may include optical means for sensing optical properties of the blood (e.g. oxygen saturation level), or they may include biochemical reagents (e.g. antibodies) to sense properties (e.g. presence of antigens) of the blood. The analyte detecting member may comprise biosensing or reagent material that will react with an analyte in blood (e.g. glucose) or other body fluid so that an appropriate signal correlating with the presence of the analyte is generated and can be read by the reader apparatus. By way of example and not limitation, analyte detecting member may be “associated with”, “mounted within”, or “coupled to” a chamber or other structure when the analyte detecting member participates in the function of providing an appropriate signal about the blood sample to the reader device. Analyte detecting member may also include nanowire analyte detecting members as described herein. Analyte detecting member may use any, singly or in combination, potentiometric, coulometric, or other method useful for detection of analyte levels.

Figures 1-11 of the accompanying drawings illustrates one embodiment of a system 10 for piercing tissue to obtain a blood sample. The system 10 may include a replaceable cartridge 12 and an apparatus 14 for removably receiving the cartridge 12 and for manipulating components of the cartridge 12.

Referring jointly to Figures 1 and 2, the cartridge 12 may include a plurality of penetrating members 18. The cartridge 12 may be in the form of a circular disc and has an outer circular surface 20 and an opening forming an inner circular surface 22. A

plurality of grooves 24 are formed in a planar surface 26 of the cartridge 12. Each groove 24 is elongated and extends radially out from a center point of the cartridge 12. Each groove 24 is formed through the outer circular surface 20. Although not shown, it should be understood that the grooves 24 are formed over the entire circumference of the planar surface 26. As shown in Figures 3 and 4, each groove 24 is relatively narrow closer to the center point of the cartridge 12 and slightly wider further from the center point. These grooves 24 may be molded into the cartridge 12, machined into the cartridge, forged, pressed, or formed using other methods useful in the manufacture of medical devices.

In the present embodiment, each penetrating member 18 has an elongated body 26 and a sharpened distal end 27 having a sharp tip 30. The penetrating member 18 may have a circular cross-section with a diameter in this embodiment of about 0.315 mm. All outer surfaces of the penetrating member 18 may have the same coefficient of friction. The penetrating member may be, but is not necessarily, a bare lancet. The lancet is "bare", in the sense that no raised formations or molded parts are formed thereon that are complementarily engageable with another structure. Traditional lancets include large plastic molded parts that are used to facilitate engagement. Unfortunately, such attachments add size and cost. In the most basic sense, a bare lancet or bare penetrating member is an elongate wire having sharpened end. If it is of sufficiently small diameter, the tip may be penetrating without having to be sharpened. A bare lancet may be bent and still be considered a bare lancet. The bare lancet in one embodiment may be made of one material.

In the present embodiment, each penetrating member 18 is located in a respective one of the grooves 24. The penetrating members 18 have their sharpened distal ends 27 pointed radially out from the center point of the cartridge 12. A proximal end of each penetrating member 15 may engage in an interference fit with opposing sides of a respective groove 24 as shown in Figure 3. Other embodiments of the cartridge 12 may not use such an interference fit. As a nonlimiting example, they may use a fracturable adhesive to releasably secure the penetrating member 18 to the cartridge 12. As shown in Figure 4, more distal portions of the penetrating member 18 are not engaged with the opposing sides of the groove 24 due to the larger spacing between the sides.

The cartridge 12 may further include a sterilization barrier 28 attached to the upper surface 26. The sterilization barrier 28 is located over the penetrating members 18 and serves to insulate the penetrating members 18 from external contaminants. The

sterilization barrier 28 is made of a material that can easily be broken when an edge of a device applies a force thereto. The sterilization barrier 28 alone or in combination with other barriers may be used to create a sterile environment about at least the tip of the penetrating member prior to lancing or actuation. The sterilization barrier 28 may be made of a variety of materials such as but not limited to metallic foil, aluminum foil, paper, polymeric material, or laminates combining any of the above. Other details of the sterilization barrier are detailed herein.

In the present embodiment, the apparatus 14 may include a housing 30, an initiator button 32, a penetrating member movement subassembly 34, a cartridge advance subassembly 36, batteries 38, a capacitor 40, a microprocessor controller 42, and switches 44. The housing 30 may have a lower portion 46 and a lid 48. The lid 48 is secured to the lower portion 46 with a hinge 50. The lower portion 46 may have a recess 52. A circular opening 54 in the lower portion 46 defines an outer boundary of the recess 52 and a level platform 56 of the lower portion 46 defines a base of the recess 52.

In use, the lid 48 of the present embodiment is pivoted into a position as shown in Figure 1. The cartridge 12 is flipped over and positioned in the recess 52. The planar surface 26 rests against the level platform 56 and the circular opening 54 contacts the outer circular surface 20 to prevent movement of the cartridge 12 in a plane thereof. The lid 48 is then pivoted in a direction 60 and closes the cartridge 12.

Referring to the embodiment shown in Figure 5, the penetrating member movement subassembly 34 includes a lever 62, a penetrating member accelerator 64, a linear actuator 66, and a spring 68. Other suitable actuators including but not limited to rotary actuators are described in commonly assigned, copending U.S. Patent Application Ser. No. 10/127,395 (Attorney Docket No. 38187-2551) filed April 19, 2002. The lever 62 may be pivotably secured to the lower portion 46. The button 32 is located in an accessible position external of the lower portion 46 and is connected by a shaft 70 through the lower portion 46 to one end of the lever 62. The penetrating member accelerator 64 is mounted to an opposing end of the lever 62. A user depresses the button 32 in an upward direction 66 so that the shaft 70 pivots the end of the lever 62 to which it is connected in an upward direction. The opposing end of the lever pivots in a downward direction 66. The spring 46 is positioned between the button 32 and the base 40 and compresses when the button 32 is depressed to create a force that tends to move the

button 32 down and pivot the penetrating member accelerator upward in a direction opposite to the direction 64.

Referring to Figures 6A and 6B in this particular embodiment, the movement of the button into the position shown in Figure 5 also causes contact between a terminal 74 on the shaft 20 with a terminal 70 secured to the lower portion 46. Contact between the terminals 74 and 76 indicates that the button 32 has been fully depressed. With the button 32 depressed, the cartridge 12 can be rotated without interference by the penetrating member actuator 64. To this effect, the cartridge advancer subsystem 36 includes a pinion gear 80 and a stepper motor 82. The stepper motor 82 is secured to the lower portion 46. The pinion gear 80 is secured to the stepper motor 82 and is rotated by the stepper motor 82. Teeth on the pinion gear 80 engage with teeth on the inner circular surface 22 of the cartridge 12. Rotation of the pinion gear 80 causes rotation of the cartridge 12 about the center point thereof. Each time that the terminals 74 and 76 make contact, the stepper motor 82 is operated to rotate the cartridge 12 through a discrete angle equal to an angular spacing from a centerline of one of the penetrating members 18 to a centerline of an adjacent penetrating member. A select penetrating member 18 is so moved over the penetrating member accelerator 64, as shown in Figure 6B. Subsequent depressions of the button 32 will cause rotation of subsequent adjacent penetrating members 18 into a position over the penetrating member accelerator 64.

The user then releases pressure from the button, as shown in Figure 7A. The force created by the spring 68 or other resilient member moves the button 32 in a downward direction 76. The shaft 70 is pivotably secured to the lever 62 so that the shaft 70 moves the end of the lever 62 to which it is connected down. The opposite end of the lever 62 pivots the penetrating member accelerator 64 upward in a direction 80. As shown in Figure 7B, an edge 82 of the penetrating member accelerator 64 breaks through a portion of the sterilization barrier 28 and comes in to physical contact with a lower side surface of the penetrating member 18.

Referring to Figure 8A, the linear actuator 66 includes separate advancing coils 86A and retracting coils 86B, and a magnetizable slug 90 within the coils 86A and 86B. The coils 86A and 86B are secured to the lower portion of 46, and the slug 90 can move within the coils 86A and 88B. Once the penetrating member accelerator 64 is located in the position shown in Figures 7A and 7B, electric current is provided to the advancing

coils 86 only. The current in the advancing coils 86 creates a force in a direction 88 on the slug 90 according to conventional principles relating to electromagnetics.

A bearing 91 is secured to the lever and the penetrating member accelerator 64 has a slot 92 over the bearing 91. The slot 92 allows for the movement of the penetrating member accelerator 64 in the direction 88 relative to the lever 62, so that the force created on the slug moves the penetrating member accelerator 64 in the direction 88.

The spring 68 is not entirely relaxed, so that the spring 68, through the lever 62, biases the penetrating member accelerator 64 against the lower side surface of the penetrating member 18 with a force F1. The penetrating member 18 rests against a base 88 of the cartridge 12. An equal and opposing force F2 is created by the base 88 on an upper side surface of the penetrating member 18.

The edge 82 of the penetrating member accelerator 64 has a much higher coefficient of friction than the base 88 of the cartridge 12. The higher coefficient of friction of the edge contributes to a relatively high friction force F3 on the lower side surface of the penetrating member 18. The relatively low coefficient of friction of the base 88 creates a relatively small friction force F4 on the upper side surface of the penetrating member 18. A difference between the force F3 and F4 is a resultant force that accelerates the penetrating member in the direction 88 relative to the cartridge 12. The penetrating member is moved out of the interference fit illustrated in Figure 3. The bare penetrating member 18 is moved without the need for any engagement formations on the penetrating member. Current devices, in contrast, often make use a plastic body molded onto each penetrating member to aid in manipulating the penetrating members. Movement of the penetrating member 18 moves the sharpened end thereof through an opening 90 in a side of the lower portion 46. The sharp end 30 of the penetrating member 18 is thereby moved from a retracted and safe position within the lower portion 46 into a position wherein it extends out of the opening 90. Accelerated, high-speed movement of the penetrating member is used so that the sharp tip 30 penetrates skin of a person. A blood sample can then be taken from the person, typically for diabetic analysis.

Reference is now made to Figures 9A and 9B. After the penetrating member is accelerated (for example, but not limitation, less than .25 seconds thereafter), the current to the accelerating coils 86A is turned off and the current is provided to the retracting coils 86B. The slug 90 moves in an opposite direction 92 together with the penetrating

member accelerator 64. The penetrating member accelerator 64 then returns the used penetrating member into its original position, i.e., the same as shown in Figure 7B.

Subsequent depression of the button as shown in Figure 5 will then cause one repetition of the process described, but with an adjacent sterile penetrating member.

5 Subsequent sterile penetrating members can so be used until all the penetrating members have been used, i.e., after one complete revolution of the cartridge 12. In this embodiment, a second revolution of the cartridge 12 is disallowed to prevent the use of penetrating members that have been used in a previous revolution and have become contaminated. The user can continue to use the apparatus 14 is by opening 'the lid 48 as
10 shown in Figure 1, removing the used cartridge 12, and replacing the used cartridge with another cartridge. A detector (not shown) detects whenever a cartridge is removed and replaced with another cartridge. Such a detector may be but is not limited to an optical sensor, an electrical contact sensor, a bar code reader, or the like.

Figure 10 illustrates the manner in which the electrical components may be
15 functionally interconnected for the present embodiment. The battery 38 provides power to the capacitor 40 and the controller 42. The terminal 76 is connected to the controller 42 so that the controller recognizes when the button 32 is depressed. The capacitor to provide power (electric potential and current) individually through the switches (such as but not limited to field-effect transistors) to the advancing coils 86A, retracting coils 86B
20 and the stepper motor 82. The switches 44A, B, and C are all under the control of the controller 42. A memory 100 is connected to the controller. A set of instructions is stored in the memory 100 and is readable by the controller 42. Further functioning of the controller 42 in combination with the terminal 76 and the switches 44A, B, and C should be evident from the foregoing description.

25 Figure 11 illustrates a configuration for another embodiment of a cartridge having penetrating members. The cartridge 112 has a corrugated configuration and a plurality of penetrating members 118 in grooves 124 formed in opposing sides of the cartridge 112. Sterilization barriers 126 and 128 are attached over the penetrating members 118 at the top and the penetrating members 118 at the bottom, respectively. Such an arrangement
30 provides large surfaces for attachment of the sterilization barriers 126 and 128. All the penetrating members 118 on the one side are used first, whereafter the cartridge 112 is turned over and the penetrating members 118 on the other side are used. Additional aspects of such a cartridge are also discussed in Figures 42-44.

Referring now to Figures 12-13, a friction based method of coupling with and driving bare lancets or bare penetrating members will be described in further detail. Any embodiment of the present invention disclosed herein may be adapted to use these methods. As seen in Figure 12, surface 201 is physically in contact with penetrating member 202. Surface 203 is also physically in contact with penetrating member 202. In the present embodiment of the invention, surface 201 is stainless steel, penetrating member 202 is stainless steel, and surface 203 is polytetrafluoroethylene-coated stainless steel.

Figure 13 illustrates one embodiment of the friction based coupling in use.

Normal force 206 may be applied vertically to surface 201, pressing it against penetrating member 202. Penetrating member 202 is thereby pressed against surface 203. Normal force 206 is transmitted through surface 201 and penetrating member 202 to also act between penetrating member 202 and surface 203. Surface 203 is held rigid or stationary with respect to a target of the lancet. Using the classical static friction model, the maximum frictional force between surface 201 and penetrating member 202 is equal to the friction coefficient between surface 201 and penetrating member 202 multiplied by the normal force between surface 201 and penetrating member 202. In this embodiment, the maximum frictional force between surface 203 and penetrating member 202 is equal to the coefficient of friction between the surface 203 and the penetrating member 202 multiplied by the normal force between the surface 203 and the penetrating member 202. Because friction coefficient between surface 203 and penetrating member 202 is less than friction coefficient between surface 201 and penetrating member 202, the interface between surface 201 and penetrating member 202 can develop a higher maximum static friction force than can the interface between surface 203 and penetrating member 202.

Driving force as indicated by arrow 207 is applied to surface 201 perpendicular to normal force 206. The sum of the forces acting horizontally on surface 201 is the sum of driving force 207 and the friction force developed at the interface of surface 201 and penetrating member 202, which acts in opposition to driving force 207. Since the coefficient of friction between surface 203 and penetrating member 202 is less than the coefficient of friction between surface 201 and penetrating member 202, penetrating member 202 and surface 201 will remain stationary with respect to each other and can be considered to behave as one piece when driving force 207 just exceeds the maximum frictional force that can be supported by the interface between surface 203 and

penetrating member 202. Surface 201 and penetrating member 202 can be considered one piece because the coefficient of friction between surface 201 and penetrating member 202 is high enough to prevent relative motion between the two.

In one embodiment, the coefficient of friction between surface 201 and
5 penetrating member 202 is approximately 0.8 corresponding to the coefficient of friction between two surfaces of stainless steel, while the coefficient of friction between surface 203 and penetrating member 202 is approximately 0.04, corresponding to the coefficient of friction between a surface of stainless steel and one of polytetrafluoroethylene. Normal force 206 has a value of 202 Newtons. Using these values, the maximum
10 frictional force that the interface between surface 201 and penetrating member 202 can support is 1.6 Newtons, while the maximum frictional force that the interface between surface 203 and penetrating member 202 can support is 0.08 Newtons. If driving force 207 exceeds 0.08 Newtons, surface 201 and penetrating member 202 will begin to accelerate together with respect to surface 203. Likewise, if driving force 207 exceeds
15 1.6 Newtons and penetrating member 202 encounters a rigid barrier, surface 201 would move relative to penetrating member 202.

Another condition, for example, for surface 201 to move relative to penetrating member 202 would be in the case of extreme acceleration. In an embodiment, penetrating member 202 has a mass of 8.24×10^{-6} kg. An acceleration of 194,174 m/s² of
20 penetrating member 202 would therefore be required to exceed the frictional force between penetrating member 202 and surface 201, corresponding to approximately 19,800 g's. Without being bound to any particular embodiment or theory of operation, other methods of applying friction base coupling may also be used. For example, the penetrating member 202 may be engaged by a coupler using an interference fit to create
25 the frictional engagement with the member.

Figure 14 illustrates a polytetrafluoroethylene coating on stainless steel surface 203 in detail. It should be understood that the surface 203 may be coated with other materials such as but not limited to Teflon®, silicon, polymer or glass. The coating may cover all of the penetrating member, only the proximal portions, only the distal portions,
30 only the tip, only some other portion, or some combination of some or all of the above. Figure 15 illustrates a doping of lead applied to surface 201, which conforms to penetrating member 202 microscopically when pressed against it. Both of these

embodiments and other coated embodiments of a penetrating member may be used with the actuation methods described herein.

The shapes and configurations of surface 201 and surface 102 could be some form other than shown in Figures 12-15. For example, surface 201 could be the surface of a wheel, which when rotated causes penetrating member 202 to advance or retract relative to surface 203. Surface 201 could be coated with another conformable material besides lead, such as but not limited to a plastic. It could also be coated with particles, such as but not limited to diamond dust, or given a surface texture to enhance the friction coefficient of surface 201 with penetrating member 202. Surface 202 could be made of or coated with diamond, fluorinated ethylene propylene, perfluoroalkoxy, a copolymer of ethylene and tetrafluoroethylene, a copolymer of ethylene and chlorotrifluoroethylene, or any other material with a coefficient of friction with penetrating member 202 lower than that of the material used for surface 201.

Referring to Figure 16, a portion of a base plate 210 of an embodiment of a penetrating member cartridge is shown with a plurality of penetrating member slots 212 disposed in a radial direction cut into a top surface 214 of the base plate. A drive member 216 is shown with a distal edge 218 disposed within one of the penetrating member slots 212 of the base plate 210. The distal edge 218 of the drive member 216 is configured to slide within the penetrating member slots 212 with a minimum of friction but with a close fit to minimize lateral movement during a lancing cycle.

Figure 17 shows a distal portion 220 of a coated penetrating member 222 in partial longitudinal section. The coated penetrating member 222 has a core portion 224, a coating 226 and a tapered distal end portion 228. A portion of a coated drive member 230 is shown having a coating 234 with penetrating member contact surface 236. The penetrating member contact surface 236 forms an interface 238 with an outer surface 240 of the coated penetrating member 222. The interface 238 has a characteristic friction coefficient that will depend in part on the choice of materials for the penetrating member coating 226 and the drive member coating 234. If silver is used as the penetrating member and drive member coating 226 and 236, this yields a friction coefficient of about 1.3 to about 1.5. Other materials can be used for coatings 226 and 236 to achieve the desired friction coefficient. For example, gold, platinum, stainless steel and other materials may be used for coatings 226 and 236. It may be desirable to use combinations of different materials for coatings 226 and 236. For example, an embodiment may

include silver for a penetrating member coating 226 and gold for a drive member coating. Some embodiments of the interface 238 can have friction coefficients of about 1.15 to about 5.0, specifically, about 1.3 to about 2.0.

Embodiments of the penetrating member 222 can have an outer transverse dimension or diameter of about 200 to about 400 microns, specifically, about 275 to about 325 microns. Embodiments of penetrating member 222 can have a length of about 10 to about 30 millimeters, specifically, about 15 to about 25 millimeters. Penetrating member 222 can be made from any suitable high strength alloy such as but not limited to stainless steel or the like.

Figure 18 is a perspective view of a lancing device 242 having features of the invention. A penetrating member cartridge 244 is disposed about a driver 246 that is coupled to a drive member 248 by a coupler rod 250. The penetrating member cartridge 244 has a plurality of penetrating member slots 252 disposed in a radial configuration in a top surface 254 a base plate 256 of the penetrating member cartridge 244. The distal ends 253 of the penetrating member slots 252 are disposed at an outer surface 260 of the base plate 256. A fractureable sterility barrier 258, shown partially cut away, is disposed on the top surface 254 of base plate 256 over the plurality of penetrating member slots 252. The sterility barrier 258 is also disposed over the outer surface 260 of the base plate 256 in order to seal the penetrating member slots from contamination prior to a lancing cycle. A distal portion of a penetrating member 262 is shown extending radially from the penetrating member cartridge 244 in the direction of a patient's finger 264.

Figure 19 illustrates a portion of the base plate 256 used with the lancing device 242 in more detail and without sterility barrier 258 in place (for ease of illustration). The base plate 256 includes a plurality of penetrating member slots 252 which are in radial alignment with corresponding drive member slots 266. The drive member slots 266 have an optional tapered input configuration that may facilitate alignment of the drive member 248 during downward movement into the drive member slot 266 and penetrating member slot 252. Penetrating member slots 252 are sized and configured to accept a penetrating member 262 disposed therein and allow axial movement of the penetrating member 262 within the penetrating member slots 252 without substantial lateral movement.

Referring again to Figure 18, in use, the present embodiment of penetrating member cartridge 242 is placed in an operational configuration with the driver 246. A lancing cycle is initiated and the drive member 248 is brought down through the sterility

barrier 258 and into a penetrating member slot 252. A penetrating member contact surface of the drive member then makes contact with an outside surface of the penetrating member 262 and is driven distally toward the patient's finger 264 as described above with regard to the embodiment discussed in Figure 20. The friction coefficient between the penetrating member contact surface of the drive member 248 and the penetrating member 262 is greater than the friction coefficient between the penetrating member 262 and an interior surface of the penetrating member slots 252. As such, the drive member 248 is able to drive the penetrating member 262 distally through the sterility barrier 258 and into the patient's finger 264 without any relative movement or substantial relative movement between the drive member 248 and the penetrating member 262.

Referring to Figures 20-22, a lancing cycle sequence is shown for a lancing device 242 with another embodiment of a penetrating member cartridge 244 as shown in Figures 23 and 24. The base plate 256 of the penetrating member cartridge 242 shown in Figures 23 and 24 has a plurality of penetrating member slots 252 with top openings 268 that do not extend radially to the outer surface 260 of the base plate 256. In this way, the penetrating member slots 252 can be sealed with a first sterility barrier 270 disposed on the top surface 254 of the base plate 256 and a second sterility barrier 272 disposed on the outer surface 260 of the base plate 256. Penetrating member outlet ports 274 are disposed at the distal ends of the penetrating member slots 252.

Referring again to Figure 20, the penetrating member 262 is shown in the proximally retracted starting position within the penetrating member slot 252. The outer surface of the penetrating member 276 is in contact with the penetrating member contact surface 278 of the drive member 248. The friction coefficient between the penetrating member contact surface 278 of the drive member 248 and the outer surface 276 of the penetrating member 262 is greater than the friction coefficient between the penetrating member 262 and an interior surface 280 of the penetrating member slots 252. A distal drive force as indicated by arrow 282 in Figure 10 is then applied via the drive coupler 250 to the drive member 248 and the penetrating member is driven out of the penetrating member outlet port 274 and into the patient's finger 264. A proximal retraction force, as indicated by arrow 284 in Figure 22, is then applied to the drive member 248 and the penetrating member 262 is withdrawn from the patient's finger 264 and back into the penetrating member slot 252.

Figures 25 and 26 illustrate an embodiment of a multiple layer sterility barrier 258 in the process of being penetrated by a penetrating member 62. It should be understood that this barrier 258 may be adapted for use with any embodiment of the present invention. The sterility barrier 258 shown in Figures 25 and 26 is a two layer sterility barrier 258 that facilitates maintaining sterility of the penetrating member 262 as it passes through and exits the sterility barrier 258. In Figure 25, the distal end 286 of the penetrating member 262 is applying an axial force in a distal direction against an inside surface 288 of a first layer 290 of the sterility barrier 258, so as to deform the first layer 290 of the sterility barrier 258. The deformation 291 of the first layer 290 in turn applies a distorting force to the second layer 292 of the sterility barrier 258. The second layer of the sterility barrier is configured to have a lower tensile strength than the first layer 290. As such, the second layer 292 fails prior to the first layer 290 due to the strain imposed on the first layer 290 by the distal end 286 of the penetrating member 262, as shown in Figure 26. After the second layer 292 fails, it then retracts from the deformed portion 291 of the first layer 290 as shown by arrows 294 in Figure 26. As long as the inside surface 288 and outside surface 296 of the first layer 290 are sterile prior to failure of the second layer 292, the penetrating member 262 will remain sterile as it passes through the first layer 290 once the first layer eventually fails. Such a multiple layer sterility barrier 258 can be used for any of the embodiments discussed herein. The multiple layer sterility barrier 258 can also include three or more layers.

Referring to Figures 27 and 28, an embodiment of a drive member 300 coupled to a driver 302 wherein the drive member 300 includes a cutting member 304 having a sharpened edge 306 which is configured to cut through a sterility barrier 258 of a penetrating member slot 252 during a lancing cycle in order for the drive member 300 to make contact with a penetrating member. An optional lock pin 308 on the cutting member 304 can be configured to engage the top surface 310 of the base plate in order to prevent distal movement of the cutting member 304 with the drive member 300 during a lancing cycle.

Figures 29 and 30 illustrate an embodiment of a penetrating member slot 316 in longitudinal section having a ramped portion 318 disposed at a distal end 320 of the penetrating member slot. A drive member 322 is shown partially disposed within the penetrating member slot 316. The drive member 322 has a cutting edge 324 at a distal end 326 thereof for cutting through a sterility barrier 328 during a lancing cycle. Figure

30 illustrates the cutting edge 324 cutting through the sterility barrier 328 during a lancing cycle with the cut sterility barrier 328 peeling away from the cutting edge 324.

Figures 31-34 illustrate drive member slots in a base plate 330 of a penetrating member cartridge wherein at least a portion of the drive member slots have a tapered opening which is larger in transverse dimension at a top surface of the base plate than at the bottom of the drive member slot. Figure 31 illustrates a base plate 330 with a penetrating member slot 332 that is tapered at the input 334 at the top surface 336 of the base plate 330 along the entire length of the penetrating member slot 332. In such a configuration, the penetrating member slot and drive member slot (not shown) would be in communication and continuous along the entire length of the slot 332. As an optional alternative, a base plate 338 as shown in Figure 32 and 33 can have a drive member slot 340 that is axially separated from the corresponding penetrating member slot 342. With this configuration, the drive member slot 340 can have a tapered configuration and the penetrating member slot 342 can have a straight walled configuration. In addition, this configuration can be used for corrugated embodiments of base plates 346 as shown in Figure 34. In Figure 34, a drive member 348 is disposed within a drive member slot 350. A penetrating member contact surface 352 is disposed on the drive member 348. The contact surface 352 has a tapered configuration that will facilitate lateral alignment of the drive member 348 with the drive member slot 350.

Figures 35-37 illustrate an embodiment of a penetrating member cartridge 360 and drive member 362 wherein the drive member 362 has contoured jaws 364 configured to grip a penetrating member shaft 366. In Figure 35, the drive member 362 and penetrating member shaft 366 are shown in transverse cross section with the contoured jaws 364 disposed about the penetrating member shaft 366. A pivot point 368 is disposed between the contoured jaws 364 and a tapered compression slot 370 in the drive member 362. A compression wedge 372 is shown disposed within the tapered compression slot 370. Insertion of the compression wedge 372 into the compression slot 370 as indicated by arrow 374, forces the contoured jaws 364 to close about and grip the penetrating member shaft 366 as indicated by arrows 376.

Figure 36 shows the drive member 362 in position about a penetrating member shaft 366 in a penetrating member slot 378 in the penetrating member cartridge 360. The drive member can be actuated by the methods discussed above with regard to other drive member and driver embodiments. Figure 37 is an elevational view in longitudinal section

of the penetrating member shaft 166 disposed within the penetrating member slot 378. The arrows 380 and 382 indicate in a general way, the path followed by the drive member 362 during a lancing cycle. During a lancing cycle, the drive member comes down into the penetrating member slot 378 as indicated by arrow 380 through an optional sterility barrier (not shown). The contoured jaws of the drive member then clamp about the penetrating member shaft 366 and move forward in a distal direction so as to drive the penetrating member into the skin of a patient as indicated by arrow 382.

Figures 38 and 39 show a portion of a lancing device 390 having a lid 392 that can be opened to expose a penetrating member cartridge cavity 394 for removal of a used penetrating member cartridge 396 and insertion of a new penetrating member cartridge 398. Depression of button 400 in the direction indicated by arrow 402 raises the drive member 404 from the surface of the penetrating member cartridge 396 by virtue of lever action about pivot point 406. Raising the lid 392 actuates the lever arm 408 in the direction indicated by arrow 410 which in turn applies a tensile force to cable 412 in the direction indicated by arrow 414. This action pulls the drive member back away from the penetrating member cartridge 396 so that the penetrating member cartridge 396 can be removed from the lancing device 390. A new penetrating member cartridge 398 can then be inserted into the lancing device 390 and the steps above reversed in order to position the drive member 404 above the penetrating member cartridge 398 in an operational position.

Figures 40 and 41 illustrate a penetrating member cartridge 420 that has penetrating member slots 422 on a top side 424 and a bottom side 426 of the penetrating member cartridge 420. This allows for a penetrating member cartridge 420 of a diameter D to store for use twice the number of penetrating members as a one sided penetrating member cartridge of the same diameter D.

Figures 42-44 illustrate end and perspective views of a penetrating member cartridge 430 having a plurality of penetrating member slots 432 formed from a corrugated surface 434 of the penetrating member cartridge 430. Penetrating members 436 are disposed on both sides of the penetrating member cartridge 430. A sterility barrier 438 is shown disposed over the penetrating member slots 432 in Figure 44.

Figures 45-48 illustrate embodiments of a penetrating member 440 and drive member 442 wherein the penetrating member 440 has a transverse slot 444 in the penetrating member shaft 446 and the drive member 442 has a protuberance 448

configured to mate with the transverse slot 444 in the penetrating member shaft 446. Figure 45 shows a protuberance 448 having a tapered configuration that matches a tapered configuration of the transverse slot 444 in the penetrating member shaft 446. Figure 46 illustrates an optional alternative embodiment wherein the protuberance 448

5 has straight walled sides that are configured to match the straight walled sides of the transverse slot 444 shown in Figure 46. Figure 47 shows a tapered protuberance 448 that is configured to leave an end gap 450 between an end of the protuberance 448 and a bottom of the transverse slot in the penetrating member shaft 446.

Figure 48 illustrates a mechanism 452 to lock the drive member 442 to the

10 penetrating member shaft 446 that has a lever arm 454 with an optional bearing 456 on the first end 458 thereof disposed within a guide slot 459 of the drive member 442. The lever arm 454 has a pivot point 460 disposed between the first end 458 of the lever arm 454 and the second end 462 of the lever arm 454. A biasing force is disposed on the second end 462 of the lever arm 454 by a spring member 464 that is disposed between the

15 second end 462 of the lever arm 454 and a base plate 466. The biasing force in the direction indicated by arrow 468 forces the penetrating member contact surface 470 of the drive member 442 against the outside surface of the penetrating member 446 and, in addition, forces the protuberance 448 of the drive member 442 into the transverse slot 444 of the penetrating member shaft 446.

20 Referring now to Figure 49, another embodiment of a replaceable cartridge 500 suitable for housing a plurality of individually moveable penetrating members (not shown) will be described in further detail. Although cartridge 500 is shown with a chamfered outer periphery, it should also be understood that less chamfered and unchamfered embodiments of the cartridge 500 may also be adapted for use with any

25 embodiment of the present invention disclosed herein. The penetrating members slidably coupled to the cartridge may be a bare lancet or bare elongate member without outer molded part or body pieces as seen in conventional lancet. The bare design reduces cost and simplifies manufacturing of penetrating members for use with the present invention. The penetrating members may be retractable and held within the cartridge so that they are

30 not able to be used again. The cartridge is replaceable with a new cartridge once all the piercing members have been used. The lancets or penetrating members may be fully contained in the used cartridge so as to minimize the chance of patient contact with such waste.

As can be seen in Figure 49, the cartridge 500 may include a plurality of cavities 501 for housing a penetrating member. In this embodiment, the cavity 501 may have a longitudinal opening 502 associated with the cavity. The cavity 501 may also have a lateral opening 503 allowing the penetrating member to exit radially outward from the cartridge. As seen in Figure 49, the outer radial portion of the cavity may be narrowed. The upper portion of this narrowed area may also be sealed or swaged to close the top portion 505 and define an enclosed opening 506 as shown in Figure 50. Optionally, the narrowed area 504 may retain an open top configuration, though in some embodiments, the foil over the gap is unbroken, preventing the penetrating member from lifting up or extending upward out of the cartridge. The narrowed portion 504 may act as a bearing and/or guide for the penetrating member. Figure 51 shows that the opening 506 may have a variety of shapes such as but not limited to, circular, rectangular, triangular, hexagonal, square, or combinations of any or all of the previous shapes. Openings 507 (shown in phantom) for other microfluidics, capillary tubes, or the like may also be incorporated in the immediate vicinity of the opening 506. In some optional embodiments, such openings 507 may be configured to surround the opening 506 in a concentric or other manner.

Referring now to Figure 52, the underside of a cartridge 500 will be described in further detail. This figure shows many features on one cartridge 500. It should be understood that a cartridge may include some, none, or all of these features, but they are shown in Figure 52 for ease of illustration. The underside may include indentations or holes 510 close to the inner periphery for purpose of properly positioning the cartridge to engage a penetrating member gripper and/or to allow an advancing device (shown in Figure 56B and 56C) to rotate the cartridge 500. Indentations or holes 511 may be formed along various locations on the underside of cartridge 500 and may assume various shapes such as but not limited to, circular, rectangular, triangular, hexagonal, square, or combinations of any or all of the previous shapes. Notches 512 may also be formed along the inner surface of the cartridge 500 to assist in alignment and/or rotation of the cartridge. It should be understood of course that some of these features may also be placed on the topside of the cartridge in areas not occupied by cavities 501 that house the penetrating members. Notches 513 may also be incorporated along the outer periphery of the cartridge. These notches 513 may be used to gather excess material from the sterility barrier 28 (not shown) that may be used to cover the angled portion 514 of the cartridge. In the present embodiment, the cartridge has a flat top surface and an angled surface

around the outside. Welding a foil type sterility barrier over that angled surface, the foil folds because of the change in the surfaces which is now at 45 degrees. This creates excess material. The grooves or notches 513 are there as a location for that excess material. Placing the foil down into those grooves 513 which may tightly stretch the material across the 45 degree angled surface. Although in this embodiment the surface is shown to be at 45 degrees, it should be understood that other angles may also be used. For example, the surface may be at any angle between about 3 degrees to 90 degrees, relative to horizontal. In some embodiments, the surface may be squared off. The surface may be unchamfered. The surface may also be a curved surface or it may be combinations of a variety of angled surfaces, curved and straight surfaces, or any combination of some or all of the above.

Referring now to Figures 53-54, the sequence in which the cartridge 500 is indexed and penetrating members are actuated will now be described. It should be understood that some steps described herein may be combined or taken out of order without departing from the spirit of the invention. These sequence of steps provides vertical and horizontal movement used with the present embodiment to load a penetrating member onto the driver.

As previously discussed, each cavity on the cartridge may be individually sealed with a foil cover or other sterile enclosure material to maintain sterility until or just before the time of use. In the present embodiment, penetrating members are released from their sterile environments just prior to actuation and are loaded onto a launcher mechanism for use. Releasing the penetrating member from the sterile environment prior to launch allows the penetrating member in the present embodiment to be actuated without having to pierce any sterile enclosure material which may dull the tip of the penetrating member or place contaminants on the member as it travels towards a target tissue. A variety of methods may be used accomplish this goal.

Figure 53A shows one embodiment of penetrating member release device, which in this embodiment is a punch plate 520 that is shown in a see-through depiction for ease of illustration. The punch plate 520 may include a first portion 521 for piercing sterile material covering the longitudinal opening 502 and a second portion 522 for piercing material covering the lateral opening 503. A slot 523 allows the penetrating member gripper to pass through the punch plate 520 and engage a penetrating member housed in the cartridge 500. The second portion 522 of the punch plate down to engage sterility

barrier angled at about a 45 degree slope. Of course, the slope of the barrier may be varied. The punch portion 522 first contacts the rear of the front pocket sterility barrier and as it goes down, the cracks runs down each side and the barrier is pressed down to the bottom of the front cavity. The rear edge of the barrier first contacted by the punch
5 portion 522 is broken off and the barrier is pressed down, substantially cleared out of the way. These features may be more clearly seen in Figure 53B. The punch portion 521 may include a blade portion down the centerline. As the punch comes down, that blade may be aligned with the center of the cavity, cutting the sterility barrier into two pieces. The wider part of the punch 521 then pushes down on the barrier so the they align parallel to
10 the sides of the cavity. This creates a complete and clear path for the gripper throughout the longitudinal opening of the cavity. Additionally, as seen in Figure 53B and 54A, a plurality of protrusion 524 are positioned to engage a cam (Figure 55A) which sequences the punching and other vertical movement of punch plate 520 and cartridge pusher 525. The drive shaft 526 from a force generator (not shown) which is used to actuate the
15 penetrating member 527.

Referring now to Figures 54A-F, the release and loading of the penetrating members are achieved in the following sequence. Figure 54A shows the release and loading mechanism in rest state with a dirty bare penetrating member 527 held in a penetrating member gripper 530. This is the condition of the device between lancing
20 events. When the time comes for the patient to initiate another lancing event, the used penetrating member is cleared and a new penetrating member is loaded, just prior to the actual lancing event. The patient begins the loading of a new penetrating member by operating a setting lever or slider to initiate the process. The setting lever may operate mechanically to rotate a cam (see Figure 55A) that moves the punch plate 520 and
25 cartridge pusher 525. A variety of mechanisms can be used to link the slider to cause rotation of the cartridge. In other embodiments, a stepper motor or other mover such as but not limited to, a pneumatic actuator, hydraulic actuator, or the like are used to drive the loading sequence.

Figure 54B shows one embodiment of penetrating member gripper 530 in more
30 detail. The penetrating member gripper 530 may be in the form of a tuning fork with sharp edges along the inside of the legs contacting the penetrating member. In some embodiments, the penetrating member may be notched, recessed, or otherwise shaped to receive the penetrating member gripper. As the gripper 530 is pushed down on the

penetrating member, the legs are spread open elastically to create a frictional grip with the penetrating member such as but not limited to bare elongate wires without attachments molded or otherwise attached thereon. In some embodiments, the penetrating member is made of a homogenous material without any additional attachments that are molded, adhered, glued or otherwise added onto the penetrating member.

In some embodiments, the gripper 530 may cut into the sides of the penetrating member. The penetrating member in one embodiment may be about 300 microns wide. The grooves that form in the side of the penetrating member by the knife edges are on the order of about 5-10 microns deep and are quite small. In this particular embodiment, the knife edges allow the apparatus to use a small insertion force to get the gripper onto the penetrating member, compared to the force to remove the penetrating member from the gripper the longitudinal axis of an elongate penetrating member. Thus, the risk of a penetrating member being detached during actuation are reduced. The gripper 530 may be made of a variety of materials such as, but not limited to high strength carbon steel that is heat treated to increased hardness, ceramic, substrates with diamond coating, composite reinforced plastic, elastomer, polymer, and sintered metals. Additionally, the steel may be surface treated. The gripper 130 may have high gripping force with low friction drag on solenoid or other driver.

As seen in Figure 54C, the sequence begins with punch plate 520 being pushed down. This results in the opening of the next sterile cavity 532. In some embodiment, this movement of punch plate 520 may also result in the crimping of the dirty penetrating member to prevent it from being used again. This crimping may result from a protrusion on the punch plate bending the penetrating member or pushing the penetrating member into a groove in the cartridge that hold the penetrating member in place through an interference fit. As seen in Figures 53B and 54C, the punch plate 520 has a protrusion or punch shaped to penetrate a longitudinal opening 502 and a lateral opening 503 on the cartridge. The first portion 521 of the punch that opens cavity 532 is shaped to first pierce the sterility barrier and then push, compresses, or otherwise moves sterile enclosure material towards the sides of the longitudinal opening 502. The second portion 522 of the punch pushes down the sterility barrier at lateral opening or penetrating member exit 503 such that the penetrating member does not pierce any materials when it is actuated toward a tissue site.

Referring now to Figure 54D, the cartridge pusher 525 is engaged by the cam 550 (not shown) and begins to push down on the cartridge 500. The punch plate 520 may also travel downward with the cartridge 500 until it is pushed down to its maximum downward position, while the penetrating member gripper 530 remains vertically stationary. This joint downward motion away from the penetrating member gripper 530 will remove the penetrating member from the gripper. The punch plate 520 essentially pushes against the penetrating member with protrusion 534 (Figure 55A), holding the penetrating member with the cartridge, while the cartridge 500 and the punch plate 520 is lowered away from the penetrating member gripper 530 which in this embodiment remains vertically stationary. This causes the stripping of the used penetrating member from the gripper 530 (Figure 45D) as the cartridge moves relative to the gripper.

At this point as seen in Figure 54E, the punch plate 520 retracts upward and the cartridge 500 is pushed fully down, clear of the gripper 530. Now cleared of obstructions and in a rotatable position, the cartridge 500 increments one pocket or cavity in the direction that brings the newly released, sterile penetrating member in cavity 532 into alignment with the penetrating member gripper 530, as seen in Figure 54F. The rotation of the cartridge occurs due to fingers engaging the holes or indentations 533 on the cartridge, as seen in Figure 54A. In some embodiments, these indentations 533 do not pass completely through cartridge 500. In other embodiments, these indentations are holes passing completely through. The cartridge has a plurality of little indentations 533 on the top surface near the center of the cartridge, along the inside diameter. In the one embodiment, the sterility barrier is cut short so as not to cover these plurality of indentations 533. It should be understood of course that these holes may be located on bottom, side or other accessible surface. These indentations 533 have two purposes. The apparatus may have one or a plurality of locator pins, static pins, or other keying feature that does not move. In this embodiment, the cartridge will only set down into positions where the gripper 530 is gripping the penetrating member. To index the cassette, the cartridge is lifted off those pins or other keyed feature, rotated around, and dropped onto those pins for the next position. The rotating device is through the use of two fingers: one is a static pawl and the other one is a sliding finger. They engage with the holes 533. The fingers are driven by a slider that may be automatically actuated or actuated by the user. This may occur mechanically or through electric or other powered devices. Halfway

through the stroke, a finger may engage and rotate around the cartridge. A more complete description can be found with text associated with Figures 56B-56C.

Referring now to Figure 54G, with the sterile penetrating member in alignment, the cartridge 500 is released as indicated by arrows 540 and brought back into contact
5 with the penetrating member gripper 530. The new penetrating member 541 is inserted into the gripper 530, and the apparatus is ready to fire once again. After launch and in between lancing events for the present embodiment, the bare lancet or penetrating member 541 is held in place by gripper 530, preventing the penetrating member from accidentally protruding or sliding out of the cartridge 500.

10 It should be understood of course, that variations can be added to the above embodiment without departing from the spirit of the invention. For example, the penetrating member 541 may be placed in a parked position in the cartridge 500 prior to launch. As seen in Figure 55A, the penetrating member may be held by a narrowed
15 portion 542 of the cartridge, creating an interference fit which pinches the proximal end of the penetrating member. Friction from the molding or cartridge holds the penetrating member during rest, preventing the penetrating member from sliding back and forth. Of course, other methods of holding the penetrating member may also be used. As seen in
20 Figure 55B prior to launch, the penetrating member gripper 530 may pull the penetrating member 541 out of the portion 542. The penetrating member 541 may remain in this portion until actuated by the solenoid or other force generator coupled to the penetrating member gripper. A cam surface 544 may be used to pull the penetrating member out of
25 the portion 542. This mechanical cam surface may be coupled to the mechanical slider driven by the patient, which may be considered a separate force generator. Thus, energy from the patient extracts the penetrating member and this reduces the drain on the device's battery if the solenoid or electric driver were to pull out the penetrating member.
The penetrating member may be moved forward a small distance (on the order of about 1 mm or less) from its parked position to pull the penetrating member from the rest position
30 gripper. After penetrating tissue, the penetrating member may be returned to the cartridge and eventually placed into the parked position. This may also occur, though not necessarily, through force provided by the patient. In one embodiment, the placing of the lancet into the parked position does not occur until the process for loading a new penetrating member is initiated by the patient. In other embodiments, the pulling out of

the parked position occurs in the same motion as the penetrating member actuation. The return into the parked position may also be considered a continuous motion.

Figure 55A also shows one embodiment of the cam and other surfaces used to coordinate the motion of the punch plate 520. For example, cam 550 in this embodiment is circular and engages the protrusions 524 on the punch plate 520 and the cartridge pusher 525. Figure 55A also more clearly shows protrusion 534 which helps to hold the penetrating member in the cartridge 500 while the penetrating member gripper 530 pulls away from the member, relatively speaking. A ratchet surface 552 that rotates with the cam 550 may be used to prevent the cam from rotating backwards. The raising and lowering of cartridge 500 and punch plate 50 used to load/unload penetrating members may be mechanically actuated by a variety of cam surfaces, springs, or the like as may be determined by one skilled in the art. Some embodiments may also use electrical or magnetic device to perform the loading, unloading, and release of bare penetrating members. Although the punch plate 520 is shown to be punching downward to displace, remove, or move the foil or other sterile environment enclosure, it should be understood that other methods such as but not limited to stripping, pulling, tearing, or some combination of one or more of these methods may be used to remove the foil or sterile enclosure. For example, in other embodiments, the punch plate 520 may be located on an underside of the cartridge and punch upward. In other embodiments, the cartridge may remain vertically stationary while other parts such as but not limited to the penetrating member gripper and punch plate move to load a sterile penetrating member on to the penetrating member gripper.

Figure 55B also shows other features that may be included in the present apparatus. A fire button 560 may be included for the user to actuate the penetrating member. A front end interface 561 may be included to allow a patient to seat their finger or other target tissue for lancing. The interface 561 may be removable to be cleaned or replaced. A visual display 562 may be included to show device status, lancing performance, error reports, or the like to the patient.

Referring now to Figure 56A, a mechanical slider 564 used by the patient to load new penetrating member may also be incorporated on the housing. The slider 564 may also be coupled to activate an LCD or visual display on the lancing apparatus. In addition to providing a source of energy to index the cartridge, the slider 564 may also switch the electronics to start the display. The user may use the display to select the depth of lancing

or other feature. The display may go back to sleep again until it is activated again by motion of the slider 564. The underside the housing 566 may also be hinged or otherwise removable to allow the insertion of cartridge 500 into the device. The cartridge 500 may be inserted using technology current used for insertion of a compact disc or other disc into a compact disc player. In one embodiment, there may be a tray which is deployed outward to receive or to remove a cartridge. The tray may be withdrawn into the apparatus where it may be elevated, lowered, or otherwise transported into position for use with the penetrating member driver. In other embodiments, the apparatus may have a slot into which the cartridge is partially inserted at which point a mechanical apparatus will assist in completing insertion of the cartridge and load the cartridge into proper position inside the apparatus. Such device is akin to the type of compact disc player found on automobiles. The insertions/ejection and loading apparatus of these compact disc players uses gears, pulleys, cables, trays, and/or other parts that may be adapted for use with the present invention.

Referring now to Figure 56B, a more detailed view of one embodiment of the slider 564 is provided. In this embodiment, the slider 564 will move initially as indicated by arrow 567. To complete the cycle, the patient will return the slider to its home position or original starting position as indicated by arrow 568. The slider 564 has an arm 569 which moves with the slider to rotate the cam 550 and engage portions 522. The motion of the slider 564 is also mechanically coupled to a finger 570 which engage the indentations 571 on cartridge 500. The finger 570 is synchronized to rotate the cartridge 500 by pulling as indicated by arrow 572 in the same plane as the cartridge. It should be understood that in some embodiments, the finger 570 pushes instead of pulls to rotate the cartridge in the correct direction. The finger 570 may also be adapted to engage ratchet surfaces 706 as seen in Figure 66 to rotate a cartridge. The finger 570 may also incorporate vertical motion to coordinate with the rising and lowering of the cartridge 500. The motion of finger 570 may also be powered by electric actuators such as but not limited to a stepper motor or other device useful for achieving motion. Figure 56B also shows a portion of the encoder 573 used in position sensing.

Referring now to Figure 56C, a still further view of the slider 564 and arm 569 is shown. The arm 569 moves to engage portion 522 as indicated by arrow 575 and this causes the cam 550 to rotate as indicated by arrow 577. In this particular embodiment, the cam 550 rotates about 1/8 of an rotation with each pull of the slider 564. When the

slider 564 is return to its home or start position, the arm 569 rides over the portion 522. The movement of the slider also allows the cam surface 544 to rotate about pivot point 579. A resilient member 580 may be coupled to the cam surface 544 to cause it to rotate counterclockwise when the arm 569 moves in the direction of arrow 567. The pin 580
5 will remain in contact with the arm 569. As the cam surface 544 rotates a first surface 582 will contact the pin 583 on the gripper block 584 and pull the pin 583 back to park a penetrating member into a coupling or narrowed portion 542 of the cartridge 500 as seen in Figure 55A. As the arm 569 is brought back to the home position, the cam surface 544 rotates back and a second surface 586 that rotates clockwise and pushes the penetrating
10 member forward to be released from the narrowed portion 542 resulting in a position as seen in Figure 55B. It should be understood that in some embodiments, the release and/or parking of lancet from portion 542 may be powered by the driver 588 without using the mechanical assistance from cam surface 544.

In another embodiment of the cartridge device, a mechanical feature may be
15 included on the cartridge so that there is only one way to load it into the apparatus. As a nonlimiting example, in one embodiment holding 50 penetrating members, the cartridge may have 51 pockets or cavities. The 51st pocket will go into the firing position when the device is loaded, thus providing a location for the gripper to rest in the cartridge without releasing a penetrating member from a sterile environment. The gripper 530 in that
20 zeroth position is inside the pocket or cavity and that is the reason why one of the pockets may be empty. Of course, some embodiments may have the gripper 530 positioned to grip a penetrating member as the cartridge 500 is loaded into the device, with the patient lancing themselves soon afterwards so that the penetrating member is not contaminated due to prolonged exposure outside the sterile enclosure. That zeroth position may be the
25 start and finish position. The cartridge may also be notched to engaged a protrusion on the apparatus, thus also providing a method for allowing the penetrating member to loaded or unloaded only in one orientation. Essentially, the cartridge 500 may be keyed or slotted in association with the apparatus so that the cartridge 500 can only be inserted or removed at one orientation. For example as seen in Figure 56D, the cartridge 592 may
30 have a keyed slot 593 that matches the outline of a protrusion 594 such that the cartridge 592 may only be removed upon alignment of the slot 593 and protrusion 594 upon at the start or end positions. It should be understood that other keyed technology may be used and the slot or key may be located on an outer periphery or other location on the cartridge

592 in manner useful for allowing insertion or removal of the cartridge from only one or a select number of orientations.

Referring now to Figure 57, a cross-section of another embodiment of a cavity 600 housing a penetrating member is shown. The cavity 600 may include a depression 5 602 for allowing the gripper 530 to penetrate sufficiently deeply into the cavity to frictionally engage the penetrating member 541. The penetrating member may also be housed in a groove 604 that holds the penetrating member in place prior to and after actuation. The penetrating member 541 is lifted upward to clear the groove 604 during actuation and exits through opening 506.

10 Referring now to Figure 58, another variation on the system according to the present invention will now be described. Figure 58 shows a lancing system 610 wherein the penetrating members have their sharpened tip pointed radially inward. The finger or other tissue of the patient is inserted through the center hole 611 to be pierced by the member 612. The penetrating member gripper 530 coupled to drive force generator 613 15 operate in substantially the same manner as described in Figures 54A-G. The punch portions 521 and 522 operate in substantially the same manner to release the penetrating members from the sterile enclosures. The punch portion 522 may be placed on the inner periphery of the device, where the penetrating member exit is now located, so that sterile enclosure material is cleared out of the path of the penetrating member exit.

20 Referring now to Figure 59, a still further variation on the lancing system according to the present invention will now be described. In the embodiments shown in Figures 53-54, the penetrating member gripper 530 approaches the penetrating member from above and at least a portion of the drive system is located in a different plane from that of the cartridge 500. Figure 59 shows an embodiment where the penetrating member 25 driver 620 is in substantially the same plane as the penetrating member 622. The coupler 624 engages a bent or L shaped portion 626 of the member 622. The cartridge 628 can rotate to engage a new penetrating member with the coupler 624 without having to move the cartridge or coupler vertically. The next penetrating member rotates into position in the slot provided by the coupler 624. A narrowed portion of the cartridge acts as a 30 penetrating member guide 630 near the distal end of the penetrating member to align the penetrating member as it exits the cartridge.

The coupler 624 may come in a variety of configurations. For example, Figure 60A shows a coupler 632 which can engage a penetrating member 633 that does not have

a bent or L-shaped portion. A radial cartridge carrying such a penetrating member 633 may rotate to slide penetrating member into the groove 634 of the coupler 632. Figure 60B is a front view showing that the coupler 632 may include a tapered portion 636 to guide the penetrating member 633 into the slot 634. Figure 60C shows an embodiment of the driver 620 using a coupler 637 having a slot 638 for receiving a T-shaped penetrating member. The coupler 637 may further include a protrusion 639 that may be guided in an overhead slot to maintain alignment of the drive shaft during actuation.

Referring now to Figure 61, a cartridge 640 for use with an in-plane driver 620 is shown. The cartridge 640 includes an empty slot 642 that allows the cartridge to be placed in position with the driver 620. In this embodiment, the empty slot 642 allows the coupler 644 to be positioned to engage an unused penetrating member 645 that may be rotated into position as shown by arrow 646. As seen in Figure 61, the cartridge 640 may also be designed so that only the portion of the penetrating member that needs to remain sterile (i.e. the portions that may actually be penetrating into tissue) are enclosed. As seen in Figure 61, a proximal portion 647 of the penetrating member is exposed. This exposed proximal portion may be about 70% of the penetrating member. In other embodiments it may be between about 69% to about 5% of the penetrating member. The cartridge 640 may further include, but not necessarily, sealing protrusions 648. These protrusions 648 are releasably coupled to the cartridge 640 and are removed from the cartridge 640 by remover 649 as the cartridge rotates to place penetrating member 645 into the position of the active penetrating member. The sterile environment is broken prior to actuation of the member 645 and the member does not penetrate sterile enclosure material that may dull the tip of the penetrating member during actuation. A fracturable seal material 650 may be applied to the member to seal against an inner peripheral portion of the cartridge.

Referring now to Figure 62, a still further embodiment of a cartridge for use with the present invention will be described. This cartridge 652 includes a tapered portion 654 for allowing the coupler 655 to enter the cavity 656. A narrowed portion 657 guides the penetrating member 658. The coupler 655 may have, but does not necessarily have, movable jaws 659 that engage to grip the penetrating member 658. Allowing the coupler to enter the cavity 656 allows the alignment of the penetrating member to be better maintained during actuation. This tapered portion 654 may be adapted for use with any embodiment of the cartridge disclosed herein.

Referring now to Figure 63, a linear cartridge 660 for use with the present invention will be described. Although the present invention has been shown in use with radial cartridges, the lancing system may be adapted for use with cartridges of other shapes. Figures 79-83 show other cartridges of varying shapes adaptable for use with the present invention. Figure 63 illustrates a cartridge 660 with only a portion 662 providing sterile protection for the penetrating members. The cartridge 660, however, provides a base 664 on which a penetrating member 665 can rest. This provides a level of protection of the penetrating member during handling. The base 664 may also be shaped to provide slots 666 in which a penetrating member 667 may be held. The slot 666 may also be adapted to have a tapered portion 668. These configurations may be adapted for use with any of the embodiments disclosed herein, such as the cartridge 652.

Referring now to Figures 64A-64C, a variety of different devices are shown for releasing the sterility seal covering a lateral opening 503 on the cartridge 500. Figure 64A shows a rotating punch device 670 that has protrusions 672 that punch out the sterility barrier creating openings 674 from which a penetrating member can exit without touching the sterility barrier material. Figure 64B shows a vertically rotating device 676 with shaped protrusions 678 that punch down the sterility barrier 679 as it is rotated to be in the active, firing position. Figure 64C shows a punch 680 which is positioned to punch out barrier 682 when the cartridge is lowered onto the punch. The cartridge is rotated and the punch 680 rotates with the cartridge. After the cartridge is rotated to the proper position and lifted up, the punch 680 is spring loaded or otherwise configured to return to the position to engage the sterility barrier covering the next unused penetrating member.

Referring now to Figure 65A-65B, another type of punch mechanism for use with a punch plate 520 will now be described. The device shown in Figures 53-54 shows a mechanism that first punches and then rotates or indexes the released penetrating member into position. In this present embodiment, the cartridge is rotated first and then the gripper and punch may move down simultaneously. Figure 65A shows one embodiment of a punch 685 having a first portion 686 and a second portion 687. As seen in cross-sectional view of Figure 65B, the penetrating member gripper 690 is located inside the punch 685. Thus the penetrating of the sterility barrier is integrated into the step of engaging the penetrating member with the gripper 690. The punch 685 may include a slot 692 allowing a portion 694 of the gripper 690 to extend upward. A lateral opening 695 is provided from which a penetrating member may exit. In some embodiments, the punch

portion 687 is not included with punch 686, instead relying on some other mechanism such as those shown in Figures 64A-64C to press down on barrier material covering a lateral opening 503.

Referring now to Figures 66, a still further embodiment of a cartridge according to the present invention will be described. Figure 66 shows a cartridge 700 with a plurality of cavities 702 and individual deflectable portions or fingers 704. The ends of the protective cavities 702 may be divided into individual fingers (such as one for each cavity) on the outer periphery of the disc. Each finger 704 may be individually sealed with a foil cover (not shown for ease of illustration) to maintain sterility until the time of use. Along the inner periphery of the cartridge 700 are raised step portions 706 to create a ratchet type mechanism. As seen in Figure 67, a penetrating member 708 may be housed in each cavity. The penetrating member may rest on a raised portion 710. A narrowed portion 712 pinches the proximal portions of the penetration member 708. Each cavity may include a wall portion 714 into which the penetrating member 708 may be driven after the penetrating member has been used. Figure 68 shows the penetrating member gripper 716 lowered to engage a penetrating member 708. For ease of illustration, a sterility barrier covering each of the cavities is not shown.

Referring now to Figures 69A-69L, the sequence of steps for actuating a penetrating member in a cartridge 700 will be described. It should be understood that in other embodiments, steps may be combined or reduced without departing from the spirit of the present invention. The last penetrating member to be used may be left in a retracted position, captured by a gripper 716. The end of the protective cavity 704 may be deflected downward by the previous actuation. The user may operate a mechanism such as but not limited to a thumbwheel, lever, crank, slider, etc...that advances a new penetrating member 720 into launch position as seen in Figure 69A. The mechanism lifts a bar that allows the protective cavity to return to its original position in the plane of the disc.

In this embodiment as shown in Figure 69B, the penetrating member guide 722 presses through foil in rear of pocket to "home" penetrating member and control vertical clearance. For ease of illustration, actuation devices for moving the penetrating member guide 722 and other mechanisms are not shown. They may be springs, cams, or other devices that can lower and move the components shown in these figures. In some

embodiments, the cartridge 700 may be raised or lowered to engage the penetrating member guide 722 and other devices.

As seen in Figure 69C, the plough or sterile enclosure release device 724 is lowered to engage the cartridge 700. In some embodiments, the disc or cartridge 700
5 may raised part way upward until a plough or plow blade 724 pierces the sterility barrier 726 which may be a foil covering.

Referring now to Figure 69D, the plough 724 clears foil from front of pocket and leaves it attached to cartridge 700. The plough 724 is driven radially inward, cutting open the sterility barrier and rolling the scrap into a coil ahead of the plough. Foil
10 naturally curls over and forms tight coil when plough lead angle is around 55degs to horizontal. If angle of the plough may be between about 60-40degs, preferably closer to 55 degs. In some embodiments, the foil may be removed in such a manner that the penetrating member does not need to pierce any sterile enclosure materials during launch.

Referring now to Figure 69E, the gripper 716 may be lowered to engage the bare
15 penetrating member or piercing member 720. Optionally, the disc or cartridge 8000 may be raised until the penetrating member 720 is pressed firmly into the gripper 716. Although not shown in the present figure, the penetrating member driver or actuator of the present embodiment may remain in the same horizontal plane as the penetrating member.

As seen in Figure 69F, a bar 730 may be pressed downward on the outer end 732
20 of the protective cavity to deflect it so it is clear of the path of the penetrating member. In the present embodiment, the bar 730 is shaped to allow the bare penetrating member 720 to pass through. It should be understood that other shapes and orientations of the bar (such as contacting only one side or part of end 732) may be used to engage the end 732.

Referring now to Figure 69G, an electrical solenoid or other electronic or feed-
25 back controllable drive may actuate the gripper 716 radially outward, carrying the bare penetrating member 720 with it. The bare penetrating member projects from the protective case and into the skin of a finger or other tissue site that has been placed over the aperture of the actuator assembly. Suitable penetrating member drivers are described
30 in commonly assigned, copending U.S. Patent Application Ser. No. 10/127,395 (Attorney Docket No. 38187-2551) filed April 19, 2002.

Referring now to Figure 69H, the solenoid or other suitable penetrating member driver retracts the bare penetrating member 720 into a retracted position where it parks until the beginning of the next lancing cycle.

Referring now to Figure 69I, bar 730 may be released so that the end 150 returns
5 to an in-plane configuration with the cartridge 800.

As seen in Figure 69J, the gripper 716 may drive a used bare penetrating member radially outward until the sharpened tip is embedded into a plastic wall 714 at or near the outward end 732 of the cavity thus immobilizing the contaminated penetrating member.

As seen in Figures 69K and 69L, the plough 724, the gripper 716, and penetrating
10 member guide 722 may all be disengaged from the bare penetrating member 720.
Optionally, it should be understood that the advance mechanism may lower the cartridge 700 from the gripper 716. The used penetrating member, restrained by the tip embedded in plastic, and by the cover foil at the opposite end, is stripped from the gripper. The disc or cartridge 700 may be rotated until a new, sealed; sterile penetrating member is in
15 position under the launch mechanism.

Referring now to Figures 70 and 71, one object for some embodiments of the invention is to include blood sampling and sensing on this penetrating member actuation device. In the present embodiment, the drive mechanism (gripper 738 and solenoid drive coil 739) may be used to drive a penetrating member into the skin and couple this lancing event to acquire the blood sample as it forms at the surface of the finger. In a first embodiment shown in Figure 70, microfluidic module 740 bearing the analyte detecting member chemistry and detection device 742 (Figure 71) is couple on to the shaft of the penetrating member 720. The drive cycle described above may also actuate the module 740 so that it rests at the surface of the finger to acquire blood once the penetrating member retracts from the wound. The module 740 is allowed to remain on the surface of the finger or other tissue site until the gripper 738 has reached the back end 744 of the microfluidics module 740, at which point the module is also retracted into the casing. The amount of time the module 740 remains on the finger, in this embodiment, may be varied based on the distance the end 744 is located and the amount of time it takes the gripper to engage it on the withdrawal stroke. The blood filled module 740, filled while the module remains on pierced tissue site, may then undergo analyte detection by means such as but not limited to optical or electrochemical sensing.

The blood may be filled in the lumen that the penetrating member was in or the module may have separately defined sample chambers to the side of the penetrating member lumen. The analyte detecting member may also be placed right at the immediate vicinity or slightly setback from the module opening receiving blood so that low blood volumes will still reach the analyte detecting member. In some embodiments, the analyte sensing device and a visual display or other interface may be on board the apparatus and thus provide a readout of analyte levels without need to plug apparatus or a test strip into a separate reader device. As seen in Figure 71, the cover 746 may also be clear to allow for light to pass through for optical sensing. The analyte detecting member may be used with low volumes such as less than about 1 microliter of sample, preferably less than about 0.6 microliter, more preferably less than about 0.3 microliter, and most preferably less than about 0.1 microliter of sample.

In another embodiment as seen in Figure 72, sensing elements 760 may be directly printed or formed on the top or bottom of the penetrating member cartridge 700, depending on orientation. The bare penetrating member 720 is then actuated through a hole 762 in the plastic facing, withdrawn into the radial cavity followed by the blood

sample. Electrochemical or optical detection for analyte sensing may then be carried out (Figure 72). Again the cavity 766 may have a clear portion to allow light to pass for optical sensing. In one embodiment, a multiplicity of miniaturized analyte detecting member fields may be placed on the floor of the radial cavity as shown in Figure 72 or on the microfluidic module shown in Figure 71 to allow many tests on a single analyte form a single drop of blood to improve accuracy and precision of measurement. Although not limited in this manner, additional analyte detecting member fields or regions may also be included for calibration or other purposes.

Referring now to Figure 73, a still further embodiment of a cartridge according to the present invention will be described. Figure 73 shows one embodiment of a cartridge 800 which may be removably inserted into an apparatus for driving penetrating members to pierce skin or tissue. The cartridge 800 has a plurality of penetrating members 802 that may be individually or otherwise selectively actuated so that the penetrating members 802 may extend outward from the cartridge, as indicated by arrow 804, to penetrate tissue. In the present embodiment, the cartridge 800 may be based on a flat disc with a number of penetrating members such as, but in no way limited to, (25, 50, 75, 100, ...) arranged radially on the disc or cartridge 800. It should be understood that although the cartridge 800 is shown as a disc or a disc-shaped housing, other shapes or configurations of the cartridge may also work without departing from the spirit of the present invention of placing a plurality of penetrating members to be engaged, singly or in some combination, by a penetrating member driver.

Each penetrating member 802 may be contained in a cavity 806 in the cartridge 800 with the penetrating member's sharpened end facing radially outward and may be in the same plane as that of the cartridge. The cavity 806 may be molded, pressed, forged, or otherwise formed in the cartridge. Although not limited in this manner, the ends of the cavities 806 may be divided into individual fingers (such as one for each cavity) on the outer periphery of the disc. The particular shape of each cavity 806 may be designed to suit the size or shape of the penetrating member therein or the amount of space desired for placement of the analyte detecting members 808. For example and not limitation, the cavity 806 may have a V-shaped cross-section, a U-shaped cross-section, C-shaped cross-section, a multi-level cross section or the other cross-sections. The opening 810 through which a penetrating member 802 may exit to penetrate tissue may also have a variety of shapes, such as but not limited to, a circular opening, a square or rectangular opening, a

U-shaped opening, a narrow opening that only allows the penetrating member to pass, an opening with more clearance on the sides, a slit, a configuration as shown in Figure 75, or the other shapes.

In this embodiment, after actuation, the penetrating member 802 is returned into
5 the cartridge and may be held within the cartridge 800 in a manner so that it is not able to be used again. By way of example and not limitation, a used penetrating member may be returned into the cartridge and held by the launcher in position until the next lancing event. At the time of the next lancing, the launcher may disengage the used penetrating member with the cartridge 800 turned or indexed to the next clean penetrating member
10 such that the cavity holding the used penetrating member is position so that it is not accessible to the user (i.e. turn away from a penetrating member exit opening). In some embodiments, the tip of a used penetrating member may be driven into a protective stop that hold the penetrating member in place after use. The cartridge 800 is replaceable with a new cartridge 800 once all the penetrating members have been used or at such other
15 time or condition as deemed desirable by the user.

Referring still to the embodiment in Figure 73, the cartridge 800 may provide sterile environments for penetrating members via seals, foils, covers, polymeric, or similar materials used to seal the cavities and provide enclosed areas for the penetrating members to rest in. In the present embodiment, a foil or seal layer 820 is applied to one
20 surface of the cartridge 800. The seal layer 820 may be made of a variety of materials such as but not limited to a metallic foil or other seal materials and may be of a tensile strength and other quality that may provide a sealed, sterile environment until the seal layer 820 is penetrate by a suitable or penetrating device providing a preselected or selected amount of force to open the sealed, sterile environment. Each cavity 806 may be
25 individually sealed with a layer 820 in a manner such that the opening of one cavity does not interfere with the sterility in an adjacent or other cavity in the cartridge 800. As seen in the embodiment of Figure 73, the seal layer 820 may be a planar material that is adhered to a top surface of the cartridge 800.

Depending on the orientation of the cartridge 800 in the penetrating member
30 driver apparatus, the seal layer 820 may be on the top surface, side surface, bottom surface, or other positioned surface. For ease of illustration and discussion of the embodiment of Figure 73, the layer 820 is placed on a top surface of the cartridge 800. The cavities 806 holding the penetrating members 802 are sealed on by the foil layer 820

and thus create the sterile environments for the penetrating members. The foil layer 820 may seal a plurality of cavities 806 or only a select number of cavities as desired.

In a still further feature of Figure 73, the cartridge 800 may optionally include a plurality of analyte detecting members 808 on a substrate 822 which may be attached to a bottom surface of the cartridge 800. The substrate may be made of a material such as, but not limited to, a polymer, a foil, or other material suitable for attaching to a cartridge and holding the analyte detecting members 808. As seen in Figure 73, the substrate 822 may hold a plurality of analyte detecting members, such as but not limited to, about 10-50, 50-100, or other combinations of analyte detecting members. This facilitates the assembly and integration of analyte detecting members 808 with cartridge 800. These analyte detecting members 808 may enable an integrated body fluid sampling system where the penetrating members 802 create a wound tract in a target tissue, which expresses body fluid that flows into the cartridge for analyte detection by at least one of the analyte detecting members 808. The substrate 822 may contain any number of analyte detecting members 808 suitable for detecting analytes in cartridge having a plurality of cavities 806. In one embodiment, many analyte detecting members 808 may be printed onto a single substrate 822 which is then adhered to the cartridge to facilitate manufacturing and simplify assembly. The analyte detecting members 808 may be electrochemical in nature. The analyte detecting members 808 may further contain enzymes, dyes, or other detectors which react when exposed to the desired analyte. Additionally, the analyte detecting members 808 may comprise of clear optical windows that allow light to pass into the body fluid for analyte analysis. The number, location, and type of analyte detecting member 808 may be varied as desired, based in part on the design of the cartridge, number of analytes to be measured, the need for analyte detecting member calibration, and the sensitivity of the analyte detecting members. If the cartridge 800 uses an analyte detecting member arrangement where the analyte detecting members are on a substrate attached to the bottom of the cartridge, there may be through holes (as shown in Figure 76), wicking elements, capillary tube or other devices on the cartridge 800 to allow body fluid to flow from the cartridge to the analyte detecting members 808 for analysis. In other configurations, the analyte detecting members 808 may be printed, formed, or otherwise located directly in the cavities housing the penetrating members 802 or areas on the cartridge surface that receive blood after lancing.

The use of the seal layer 820 and substrate or analyte detecting member layer 822 may facilitate the manufacture of these cartridges 10. For example, a single seal layer 820 may be adhered, attached, or otherwise coupled to the cartridge 800 as indicated by arrows 824 to seal many of the cavities 806 at one time. A sheet 822 of analyte detecting members may also be adhered, attached, or otherwise coupled to the cartridge 800 as indicated by arrows 825 to provide many analyte detecting members on the cartridge at one time. During manufacturing of one embodiment of the present invention, the cartridge 800 may be loaded with penetrating members 802, sealed with layer 820 and a temporary layer (not shown) on the bottom where substrate 822 would later go, to provide a sealed environment for the penetrating members. This assembly with the temporary bottom layer is then taken to be sterilized. After sterilization, the assembly is taken to a clean room (or it may already be in a clean room or equivalent environment) where the temporary bottom layer is removed and the substrate 822 with analyte detecting members is coupled to the cartridge as shown in Figure 73. This process allows for the sterile assembly of the cartridge with the penetrating members 802 using processes and/or temperatures that may degrade the accuracy or functionality of the analyte detecting members on substrate 822. As a nonlimiting example, the entire cartridge 800 may then be placed in a further sealed container such as but not limited to a pouch, bag, plastic molded container, etc., to facilitate contact, improve ruggedness, and/or allow for easier handling.

In some embodiments, more than one seal layer 820 may be used to seal the cavities 806. As examples of some embodiments, multiple layers may be placed over each cavity 806, half or some selected portion of the cavities may be sealed with one layer with the other half or selected portion of the cavities sealed with another sheet or layer, different shaped cavities may use different seal layer, or the like. The seal layer 820 may have different physical properties, such as those covering the penetrating members 802 near the end of the cartridge may have a different color such as but not limited to red to indicate to the user (if visually inspectable) that the user is down to say 10, 5, or other number of penetrating members before the cartridge should be changed out.

Referring now to Figures 74 and 75, one embodiment of the microfluidics used with the analyte detecting members 808 in cartridge 800 will now be described. For ease of illustration, the shape of cavity 806 has been simplified into a simple wedge shape. It

should be understood that more sophisticated configurations such as but not limited to that shown in Figure 73 may be used. Figure 74 shows a channel 826 that assists in drawing body fluid towards the analyte detecting members 808. In the present embodiment, two analyte detecting members 808 are shown in the cavity 806. This is purely for illustrative purposes as the cavity 806 may have one analyte detecting member or any other number of analyte detecting members as desired. Body fluid entering cavity 806, while filling part of the cavity, will also be drawn by capillary action through the groove 826 towards the analyte detecting members 808. The analyte detecting members 808 may all perform the same analysis, they may each perform different types of analysis, or there may be some combination of the two (some sensors perform same analysis while others perform other analysis).

Figure 75 shows a perspective view of a cutout of the cavity 806. The penetrating member 802 (shown in phantom) is housed in the cavity 806 and may extend outward through a penetrating member exit opening 830 as indicated by arrow 832. The position of the tip of penetrating member 802 may vary, such as but not limited to being near the penetrating member exit port or spaced apart from the exit. The location of the tip relative to the analyte detecting member 808 may also be varied, such as but not limited to being spaced apart or away from the analyte detecting member or collocated or in the immediate vicinity of the analyte detecting member. Fluid may then enter the cavity 806 and directed by channel 826. The channel 826 as shown in Figure 75 is a groove that is open on top. The channel 826 may be entirely a groove with an open top or it may have a portion that is has a sealed top forming a lumen, or still further, the groove may be closed except for an opening near the penetrating member exit opening 830. It should be understood that capillary action can be achieved using a groove having one surface uncovered. In some embodiments, the analyte detecting member 808 is positioned close to the penetrating member exit opening 830 so that the analyte detecting member 808 may not need a capillary groove or channel to draw body fluid, such as in Figure 78.

As seen in Figures 75 and 76, the cavity 806 may include the substrate 822 coupled to its bottom surface containing the analyte detecting members 808. With the analyte detecting members 808 located on the underside of the cartridge 800 as seen in the embodiment of Figure 76, the cartridge 800 may include at least one through hole 834 to provide a passage for body fluid to pass from the cavity 806 to the analyte detecting member 808. The size, location, shape, and other features of the through hole 834 may be

varied based on the cavity 806 and number of analyte detecting members 808 to be provided. In other embodiments, wicking elements or the like may be used to draw body fluid from the groove 826 to down to the analyte detecting member 808 via the through hole or holes 834.

5 Referring now to Figure 77, a variety of groove and analyte detecting member configurations are shown on a single cartridge. These configurations are shown only for illustrative purposes and a single cartridge may not incorporate each of these configurations. Some embodiments may use any of the detecting members, singly or in combination. It should be understood, however, that analyte detecting member
10 configuration could be customized for each cavity, such as but not limited to, using a different number and location of analyte detecting members depending lancing variables associated with that cavity, such as but not limited to, the time of day of the lancing event, the type of analyte to be measured, the test site to be lanced, stratum corneum hydration, or other lancing parameter. As a nonlimiting example, the detecting members may be
15 moved closer towards the outer edge of the disc, more on the side walls, any combination, or the like.

Figure 77 shows a penetrating member 802 in a cavity 838 with three analyte detecting members 808 in the cavity. For ease of illustration, the penetrating member 802 is omitted from the remaining cavities so that the analyte detecting member
20 configurations can be more easily seen. Cavity 840 has a channel 826 with two analyte detecting members 808. Cavity 842 has a channel 844 coupled to a single analyte detecting member 808. Cavities 846 and 848 have one and two analyte detecting members 808, respectively. The analyte detecting members 808 in those cavities may be located directly at the penetrating member exit from the cartridge or substantially at the
25 penetrating member exit. Other analyte detecting member configurations are also possible, such as but not limited to, placing one or more analyte detecting members on a side wall of the cavity, placing the analyte detecting members in particular arrays (for example, a linear array, triangular array, square array, etc...) on the side wall or bottom surface, using mixed types of analyte detecting members (for example, electrochemical
30 and optical, or some other combination), or mixed positioning of analyte detecting members (for example, at least one analyte detecting member on the substrate below the cartridge and at least one analyte detecting member in the cavity).

Figure 78 shows an embodiment of cartridge 800 where the analyte detecting member 850 is located near the distal end of cavity 806. The analyte detecting member 850 may be formed, deposited, or otherwise attached there to the cartridge 800. In another embodiment, the analyte detecting member 850 may be a well or indentation having a bottom with sufficient transparency to allow an optical analyte detecting member to detect analytes in fluid deposited in the well or indentation. The well or indentation may also include some analyte reagent that reacts (fluoresces, changes colors, or presents other detectable qualities) when body fluid is placed in the well. In a still further embodiment, analyte detecting member 850 may be replaced with a through hole that allow fluid to pass there through. An analyte detecting member 808 on a substrate 822 may be attached to the underside of the cartridge 800, accessing fluid passing from the cavity 806 down to the analyte detecting member 808.

As mentioned above, the analyte detecting members 808 may also be placed right at the immediate vicinity or slightly setback from the module opening receiving blood so that low blood volumes will still reach the analyte detecting member. The analyte detecting members 808 may be used with low volumes such as less than about 1 microliter of sample, preferably less than about 0.6 microliter, more preferably less than about 0.3 microliter, and most preferably less than about 0.1 microliter of sample. Analyte detecting members 808 may also be directly printed or formed on the bottom of the penetrating member cartridge 800. In one embodiment, a multiplicity of miniaturized analyte detecting member fields may be placed on the floor of the radial cavity or on the microfluidic module to allow many tests on a single analyte from a single drop of blood to improve accuracy and precision of measurement. Although not limited in this manner, additional analyte detecting member fields or regions may also be included for calibration or other purposes.

Referring now to Figures 79-84, further embodiments of the cartridge 800 will now be described. Figure 79 shows a cartridge 860 having a half-circular shape. Figure 80 shows a cartridge 862 in the shape of a partial curve. Figure 80 also shows that the cartridges 862 may be stacked in various configurations such as but not limited to vertically, horizontally, or in other orientations. Figure 81 shows a cartridge 864 having a substantially straight, linear configuration. Figure 82 shows a plurality of cartridges 864 arranged to extend radially outward from a center 866. Each cartridge may be on a slide (not shown for simplicity) that allows the cartridge 864 to slide radially outward to be

aligned with a penetrating member launcher. After use, the cartridge 864 is slide back towards the center 866 and the entire assembly is rotated as indicated by arrow 868 to bring a new cartridge 864 into position for use with a penetrating member driver. Figure 83 shows a still further embodiment where a plurality of cartridges 800 may be stacked for use with a penetrating member driver (see Figure 85). The driver may be moved to align itself with each cartridge 800 or the cartridges may be moved to align themselves with the driver. Figure 84 shows a still further embodiment where a plurality of cartridge 864 are coupled together with a flexible support to define an array. A roller 870 may be used to move the cartridges 864 into position to be actuated by the penetrating member driver 872.

Referring now to Figure 85, one embodiment of an apparatus 880 using a radial cartridge 800 with a penetrating member driver 882 is shown. A contoured surface 884 is located near a penetrating member exit port 886, allowing for a patient to place their finger in position for lancing. Although not shown, the apparatus 880 may include a human readable or other type of visual display to relay status to the user. The display may also show measured analyte levels or other measurement or feedback to the user without the need to plug apparatus 880 or a separate test strip into a separate analyte reader device. The apparatus 880 may include a processor or other logic for actuating the penetrating member or for measuring the analyte levels. The cartridge 800 may be loaded into the apparatus 880 by opening a top housing of the apparatus which may be hinged or removably coupled to a bottom housing. The cartridge 800 may also drawn into the apparatus 880 using a loading mechanism similar in spirit to that found on a compact disc player or the like. In such an embodiment, the apparatus may have a slot (similar to a CD player in an automobile) that allows for the insertion of the cartridge 800 into the apparatus 880 which is then automatically loaded into position or otherwise seated in the apparatus for operation therein. The loading mechanism may be mechanically powered or electrically powered. In some embodiments, the loading mechanism may use a loading tray in addition to the slot. The slot may be placed higher on the housing so that the cartridge 800 will have enough clearance to be loaded into the device and then dropped down over the penetrating member driver 882. The cartridge 800 may have an indicator mark or indexing device that allows the cartridge to be properly aligned by the loading mechanism or an aligning mechanism once the cartridge 800 is placed into the apparatus 880. The cartridge 800 may rest on a radial platform that rotates about the penetrating

member driver 882, thus providing a method for advancing the cartridge to bring unused penetrating members to engagement with the penetrating member driver. The cartridge 800 on its underside or other surface, may shaped or contoured such as but not limited to with notches, grooves, tractor holes, optical markers, or the like to facilitate handling and/or indexing of the cartridge. These shapes or surfaces may also be varied so as to indicate that the cartridge is almost out of unused penetrating members, that there are only five penetrating members left, or some other cartridge status indicator as desired.

A suitable method and apparatus for loading penetrating members has been described previously in commonly assigned, copending U.S. patent applications Attorney Docket 38187-2589 and 38187-2590, and are included here by reference for all purposes. Suitable devices for engaging the penetrating members and for removing protective materials associated with the penetrating member cavity are described in commonly assigned, copending U.S. patent applications Attorney Docket 38187-2601 and 38187-2602, and are included here by reference for all purposes. For example in the embodiment of Figure 78, the foil or seal layer 820 may cover the cavity by extending across the cavity along a top surface 890 and down along the angled surface 892 to provide a sealed, sterile environment for the penetrating member and analyte detecting members therein. A piercing element described in U.S. patent applications Attorney Docket 38187-2602 has a piercing element and then a shaped portion behind the element which pushes the foil to the sides of the cavity or other position so that the penetrating member 802 may be actuated and body fluid may flow into the cavity.

Referring now to Figure 86, a still further embodiment of a lancing system according to the present invention will be described. A radial cartridge 500 may be incorporated for use with a penetrating member driver 882. A penetrating member may be driven outward as indicated by arrow 894. A plurality of analyte detecting members are presented on a roll 895 that is laid out near a penetrating member exit. The roll 895 may be advanced as indicated by arrow 896 so that used analyte detecting members are moved away from the active site. The roll 895 may also be replaced by a disc holding a plurality of analyte detecting members, wherein the analyte detecting member disc (not shown) is oriented in a plane substantially orthogonal to the plane of cartridge 500. The analyte detecting member disc may also be at other angles not parallel to the plane of cartridge 500 so as to be able to rotate and present new, unused analyte detecting member in sequence with new unused penetrating members of cartridge 500.

Referring now to Figure 87A, the cartridge 500 provides a high density packaging system for a lancing system. This form factor allows a patient to load a large number penetrating members through a single cartridge while maintaining a substantially handheld device. Of course such a cartridge 500 may also be used in non-handheld devices. The present cartridge 500 provide a high test density per volume of the disposable. For embodiments of a cartridge that includes analyte detecting members in addition to penetrating members such as cartridge 800, the density may also be measured in terms of density of analyte detecting members and penetrating members in a disposable. In other embodiments, the density may also be expressed in terms of analyte detecting members per disposable. For example, by taking the physical volume of one embodiment or the total envelope, this number can be divided by the number of penetrating members or number of tests. This result is the volume per penetrating member or per test in a cassetted fashion. For example, in one embodiment of the present invention, the total volume of the cartridge 500 is determined to be 4.53 cubic centimeters. In this one embodiment, the cartridge 500 holds 50 penetrating members. Dividing the volume by 50, the volume per test is arrived at 0.090 cubic centimeters. Conventional test devices such as drum is in the range of 0.720 or 0.670 cubic centimeters and that is simply the volume to hold a plurality of test strips. This does not include penetrating members as does the present embodiment 800. Thus, the present embodiment is at a substantially higher density. Even a slightly lower density device having penetrating members and analyte detecting members in the 0.500 cubic centimeter range would be a vast improvement over known devices since the numbers listed above for known devices does not include penetrating members, only packaging per test strip. Cartridges having volumes less than 4.53 may also be used.

Each penetrating member (or penetrating member and analyte detecting member, as the case may be) may have a packing density, or occupied volume, in cartridge 500. In various embodiments, the packing density or occupied volume of each penetrating member in cartridge 500 may be no more than about 0.66 cm^3 , 0.05 cm^3 , 0.4 cm^3 , 0.3 cm^3 , 0.2 cm^3 , 0.1 cm^3 , 0.075 cm^3 , 0.05 cm^3 , 0.025 cm^3 , 0.01 cm^3 , 0.090 cm^3 , 0.080 cm^3 , and the like. These numbers applicable to volumes for penetrating members alone, for combined penetrating members and analyte detecting members, and/or just analyte detecting members. In other words, the volume required for each penetrating member does not exceed $0.66 \text{ cm}^3/\text{penetrating member}$, $0.05 \text{ cm}^3/\text{penetrating member}$, 0.4

cm³/penetrating member, 0.3 cm³/penetrating member, 0.2 cm³/penetrating member, 0.1 cm³/penetrating member, 0.075 cm³/penetrating member, 0.05 cm³/penetrating member, 0.025 cm³/penetrating member, 0.01 cm³/penetrating member, 0.090 cm³/penetrating member and the like. So, if the total package volume of the cartridge is defined as X and the cartridge includes Y number of penetrating members, penetrating members and test area, or other unit 395, the volume for each unit does not exceed 0.66 cm³, 0.05 cm³, 0.4 cm³, 0.3 cm³, 0.2 cm³, 0.1 cm³, 0.075 cm³, 0.05 cm³, 0.025 cm³, 0.01 cm³, 0.090 cm³, 0.080 cm³, and the like.

Referring now to Figure 87B, a still further embodiment of a cartridge according to the present invention will now be described. Figure 87B shows a cross-section of a conical shaped cartridge with the penetrating member being oriented in one embodiment to move radially outward as indicated by arrow 897. In another embodiment, the penetrating member may be oriented to move radially inward as indicated by arrow 895. The gripper may be positioned to engage the penetrating member from an inner surface or an outer surface of the cartridge.

Referring now to Figure 88, nanowires may also be used to create low volume analyte detecting members used with the cartridge 800. Further details of a nanowire device is described in commonly assigned, copending U.S. Provisional Patent Application Ser. No. 60/433,286 (Attorney Docket No. 38187-2605) filed December 13, 2002, fully incorporated herein by reference for all purposes. These nanowire analyte detecting members 898 may be incorporated into the cavity 806 housing the penetrating member 802. They may be placed on the floor or bottom surface of the cavity 806, on the wall, on the top surface, or any combinations of some or all of these possibilities. The analyte detecting members 898 may be designed to have different sensitivity ranges so as to enhance the overall sensitivity of an array of such analyte detecting members. Methods to achieve this may include, but are not limited to, using nanowires of varying sizes, varying the number of nanowires, or varying the amount of glucose oxidase or other glucose detection material on the nanowires. These nanowire analyte detecting members may be designed to use low volumes of body fluid for each sample, due to their size. In some embodiments, each of the analyte detecting members are accurate using volumes of body fluid sample less than about 500 nanoliters. In some embodiments, each of the analyte detecting members are accurate using volumes of body fluid sample less than about 300 nanoliters. In still other embodiments, each analyte detecting member is

accurate with less than about 50 nanoliters, less than about 30 nanoliters, less than about 10 nanoliters, less than about 5 nanoliters, and less than about 1 nanoliters of body fluid sample. In some embodiments, the combined array of analyte detecting members uses less than 300 nanoliters of body fluid to arrive at an analyte measurement.

5 Referring now to Figure 89, a still further embodiment of the present invention will be described. Figure 89 shows one embodiment of an optical illumination system 910 for use with optical analyte detecting members (Figure 91) that may be in contact with a body fluid sample. The overall system may include a plurality of analyte detecting members which provide some optical indicator, a light source 912 for providing light to
10 shine on the analyte detecting members, at least one light detector 914, and a processor (not shown). The analyte detecting member or analyte detecting members are exposed to a sample of the fluid of unknown composition. A plurality of analyte detecting members may be arranged into an array of analyte detecting members exposed to one fluid sample, each group targeting a specific analyte and may contain an analyte-specific chemical that
15 interacts more specifically with one analyte than with some other analytes to be analyzed. Each analyte detecting member may also have different sensitivity ranges so as to maximize overall sensitivity of an array of such analyte detecting members. The light source 912 shines light on at least one analyte detecting member to cause light interaction. The differences in the analyte detecting members may lead to differences in
20 the light interaction. The light detector detects the light interaction by the analyte detecting members. The processor analyzes the light interaction by the analyte detecting members to take into account interference in light interaction among the analytes, thereby determining the concentration of the desired analyte in the fluid.

Referring still to the embodiment of Figure 89, the light source 912 may be but is
25 not limited to an LED. An alternative LED 915 may also be used with the present invention. Light, illumination, or excitation energy from LED 912 travels along a path through a pinhole 916, a filter 917, and a lens 918. The light then comes into contact with a beamsplitter 919 such as but not limited to a dichroic mirror or other device useful for beamsplitting. The light is then directed towards lens 920 as indicated by arrow 921. The
30 lens 920 focuses light onto the analyte detecting member (Figure 91). This excitation energy may cause a detectable optical indicator from the analyte detecting member. By way of example and not limitation, fluorescence energy may be reflected bay up the lens 920. This energy passes through the beamsplitter 919 and to lens 922 which is then

received by detector 914 as indicated by arrow 923. The detector 914 measures the energy and this information is passed on to the processor (not shown) to determine analyte levels. The illumination system 910 may also include cells 924 on the disc surface. In this specific embodiment, a penetrating member 925 drive by a force
5 generator 926 such as but not limited to a solenoid may be used to obtain the fluid sample. A detent 927 may also be included with the device along with other bare lancets or penetrating members 928.

Referring now to Figure 90, another embodiment of the illumination system 910 is shown for use with a cartridge 929. Cartridge 929 is similar to cartridge 800. Cartridge
10 929 is a single cartridge having a plurality of penetrating members and a plurality of optical analyte detecting members (not shown). The cartridge 929 further includes a plurality of optically transparent portions 930 which may be but is not limited to windows or the like for the light from LED 912 to shine into a cavity of the cartridge 929. In one embodiment, each cavity of the cartridge 929 may include at least one transparent portion
15 930. This allows the light to generate energy that may be read by analyte detecting member 914. The cartridge 929 may be used a driver 882 to actuate penetrating members and the cartridge 929 may rotate as indicated by arrow 931.

Referring now to Figure 91, a cross-section of a similar embodiment of the illumination system is shown. This system 932 has source 912 with a lens 933 having an
20 excitation filter 934. This excitation filter 934, in one embodiment, only allows excitation energy to pass. This filter 934 allows the excitation energy to pass to dichroic mirror 935, but does not let it return to source 912. Excitation energy is reflected down as indicated by arrow 936. Lens 937 focuses the energy to optical analyte detecting member 938. Fluorescence energy 939 passes through the dichroic mirror 935 and towards a
25 fluorescent filter 940. In one embodiment, the fluorescent filter 940 only allows fluorescent energy to pass through to lens 941. Thus, the detector 914 only receives fluorescent energy from the analyte detecting member 938. It should be understood of course, that the filter may be changed to allow the type of energy being generated by analyte detecting member 938 to pass. In some embodiments, no filter may be used. The
30 dichroic mirror 935 may be a Bk7 substrate, 63x40x8mm. The filters may also be a Bk7 substrate about 40mm in diameter and about 6mm thick. The lens 933, 937, and 941 may be achomat: bfl=53.6, working aperture 38mm.

Referring now to Figure 92, a still further embodiment of an illumination system 942 will be described. This system does not use a beamsplitter or dichroic mirror. Instead, both the source or LED 912 and detector 914 have direct line of sight to the optical analyte detecting member 938. In this embodiment, multiple elements are combined into a single housing. For example, lens 943, lens 944, and filter 945 are
5 combined while lens 946, lens 947, and filter 948 are also combined.

Referring now to Figure 93, a cross-section of a system similar to that of Figure 89 is shown in a housing 950. LED 912 sends light to mirror 919 to a light path 951 to cells 924 on a surface of the disc. A finger access 952 allows a sample to be obtained and
10 flow along a fluid pathway 953 to be analyzed. A processor 954 may be coupled to detector 914 to analyze the results.

Referring now to Figure 94, a cross-section of a system similar to that of Figure 90 will be further described. This shows a cartridge 929 used with a driver 882. This allows for a radial design where the penetrating members extend radially outward as
15 indicated by arrow 955. The driver 882 may have a coupler portion that reciprocates as indicated by arrow 956. Figures 95 and 96 provide further views of a system similar to that of Figure 89. The embodiment of Figures 95 and 96 may include additional lenses or filters as may be useful to refine energy detection.

Referring now to Figure 97, one embodiment of a tissue penetrating device 1000 for use with digitally encoded information will now be described. A user interface 1002, including but not limited to an optical read out, and one or more detectors 1004 may be provided on the device. As a nonlimiting example, the detector 1004 can be a CMOS.

5 The detector 1004 may provide a mechanism for digitally reading encoded information associated with the cartridge 1006, or any other information or aspect of the operation, use, and the like of the tissue penetrating system.

The tissue penetrating device 1000 may also include memory 1008. The memory 1008 can also include digitally encoded information associated with the tissue penetrating systems and its use. Examples of the digitally encoded information include but are not limited to number of penetrating members used, number of target tissue penetrating events, time and date of the last selected number of target tissue penetrating events, time interval between alarm and target tissue penetrating event, stratum corneum thickness, time of day, energy consumed by a penetrating member driver to drive a penetrating member into the target tissue, depth of penetrating member penetration, velocity of the penetrating member, desired velocity profile, velocity of the penetrating member into the target tissue, velocity of the penetrating member out of the target tissue, dwell time of the penetrating member in the target tissue, a target tissue relaxation parameter, force delivered on the target tissue, dwell time of the penetrating member, battery status, system status, consumed energy, speed profile of the penetrating member as the penetrating member penetrates and advances through the target tissue, a tissue target tissue relaxation parameter, information relative to contact of a penetrating member with target tissue before penetration by the penetrating member, information relative to a change of speed of a penetrating member as it travels in the target tissue, type of electrochemical analyte detecting member used, the kind of test the analyte detecting member will be measuring, information relative to consumed sensors and/or information relative to consumed penetrating members. These features may also be included on a device without a lancing capability. Such a device may function mainly as an analyte detecting meter and may be designed to hold a cartridge that can be used for multiple measurement events.

10
15
20
25
30

The digitally encoded information may be read via the user interface. It should be understood that bar coding and other techniques for relating information may also be used with the present invention.

Referring now to Figure 98, one embodiment of a tissue penetrating device 1000 with an optical detection system that separates excitation and fluorescence images will now be described. One or more optical detectors or imagers 1010 are provided. In one embodiment, a grating 1012 is positioned at an aperture plane of a lens L. Excitation radiation is directed at an object O. In this embodiment, the object O may be a well with emulsions or other chemical compounds to detect the presence of at least one analyte. In the plane of the detector 1010, the diffraction of the grating 1012 causes the fluorescence image λ_f and excitation image λ_e to be separated. As a nonlimiting example, the detector 1010 can be a CMOS or CMOS array. This permits the excitation and fluorescence images to be separately detected.

As seen in Figure 98, the lens aperture plane grating 1012 uses diffraction to separate the excitation image and fluorescent image. The filter 1014 may be used to attenuate the excitation so that saturation of the detector 1010 (which in this embodiment may be a CMOS array) can be prevented. The aim is to provide maximum focal plane information and reduce the need for a dichroic beamsplitter (although such a beamsplitter may be used in alternative embodiments). It should be understood that in some embodiments, a GRIN lens array may be used in place of lens L. Splitting of the image may allow for more accurate detection of the fluorescence image. Splitting may reduce the amount of noise associated with the fluorescence image. Splitting may also allow for referencing of the displaced images. The optical train of Figure 98 may be adapted for use with the embodiments described in Figures 89-96 and with any of the embodiments disclosed herein. Although not limited to the following, the displaced images may be directed at one CMOS, one CMOS array, separate CMOS's, or separate CMOS arrays.

As described above, the tissue penetrating device such as but not limited to device 1000 may use photodetector arrays for fluorescence lifetime imaging to determine analyte levels. In one embodiment of the present invention, CMOS detector arrays are utilized to measure fluorescence lifetimes of the analyte detecting members. In one embodiment, each pixel in the array has a plurality of charge/voltage storage locations. A sample of the correct pixel light level can be stored at one or more of these storage locations, as illustrated in Figure 99.

Referring now to Figure 100, a time dependent optical image can be sampled and averaged, or integrated, on the array. This integration, as a function of time, is illustrated in Figure 100. In the figure, "A" represents the averaged/integrated time dependent

optical image on one capacitor. "B" is the averaged/integrated time dependent optical image on a different capacitor. A processor (not shown) in the device 1000 may be used to determine analyte levels using this lifetime information. Although not limited to the following, the capacitor may be on the cartridge or on the device 1000.

5 Referring now to Figure 101, one embodiment of a tissue penetrating device and/or an analyte detecting meter, such as but not limited to device 1000, with a diffuser for illuminating well regions with homogenized light will now be described. In an optical detection system, in one embodiment, a diffuser 1020 may be utilized to uniformly illuminate several discrete analyte regions of wells 1022 from an extended light source
10 1024, including but not limited to LED's and the like.

In one embodiment, custom diffractive optical elements, including but not limited to kinoforms, illustrated in Figure 102, can modify the phase in front of a focal plane of a lens to produce a highly uniform set of spots in back of the focal plane. Diffraction is utilized to rearrange the light fields. Algorithms, including but not limited to Gerchberg-Saxton, can be used to calculate the phase of the appropriate diffractive element in order
15 to create an arbitrary distribution at the wells. The result is computation of a phase distribution that converts a light field, such as but not limited to that of an LED, to a specific and custom light distribution by means of diffraction. It should be understood that controller or processor associated with the tissue penetrating device 1000 may
20 include logic for performing the phase and other calculations described above.

Referring now to Figure 103, one embodiment of a tissue penetrating device and/or an analyte detecting meter with a device that maintains image quality of the wells will now be described. In one embodiment, the wells 1030 are maintained in focus through a combination of a light source 1032, an object, viewing lens 1034 and a detector
25 1036. If a well is warped, or becomes warped, and out of plane, the focus of the wells is maintained irrespective of the warping by use of a specific geometry to maintain focus. This corrects for out of plane errors of the wells. The lens position may be adjustable as indicated by arrows 1038. They may be movable in vertical, horizontal, tilted or other orientation other than shown by arrows in the Figure 103.

30 Referring now to Figure 104, one embodiment of a tissue penetrating device and/or an analyte detecting meter with auto fluorescence to reduce noise will now be described. In one embodiment, the effects of light that can interfere with a reading from the wells are removed. Examples of interfering light include but are not limited to, back-

scattered illumination, auto fluorescence from the sample chamber, and the like. In this embodiment, interfering light levels from representative areas of the substrate that do not contain measurement signal. This is then used to compute the corrections for reading the response from the analyte detecting members in the wells. In one embodiment, the measurement may be made by a separate detector CMOS 1040. In one embodiment, a separate source 1042 (shown in phantom) maybe used and aimed at a non-well portion of the object.

Referring now to Figure 105, one embodiment of a tissue penetrating device and/or an analyte detecting meter with a dual luminescent analyte detecting member will now be described. In one embodiment, the analyte sensing system is a dual luminescent analyte detecting system that utilizes luminescent beads 1050 of the same color with different non-overlapping lifetimes ranges for their particular analyte. A slurry is laid over a well. Different portions of the slurry can be selected to be an oxygen sensor, a glucose sensor, and the like. The slurry has all of the properties needed for one or more analytes to be detected and/or measured. In one embodiment, the sample is selectively dispersed to different parts of the slurry with separate areas as demarked by dotted line 1052. Activation is dependent on the slurry and/or what is deposited. It should be understood that triple and other luminescent detecting systems may also be used.

Referring now to Figure 106, one embodiment of a tissue penetrating device and/or an analyte detecting meter with a star geometry of wells will now be described. In one embodiment, a plurality of wells such as but not limited to W1 to W4 are provided and are arranged with a central fluid input port 1060 for receiving a body fluid with one or more analytes. The plurality of wells W1-W4 are coupled to the common input port 1060. In one specific embodiment, the wells are arranged in a star configuration, as illustrated in Figure 106. Use of the common input port, which can be centrally positioned relative to each well W, and/or positioned the same distance from each well, provides that fluid is evenly distributed to each well. It should be understood that other configurations such as but not limited Y, asterisk, and other as shown in Figure 107A may also be used. These wells may be combined with any of the cartridges described herein, such as but not limited to cartridge 500. In some embodiments, more than one well is associated with each glucose test event as seen in Figure 107B. The disc-shaped cartridge 500 may have some, none, all, or combinations of the star and other shaped wells. The embodiment of Figure 107B is purely exemplary.

Referring now to Figure 108, one embodiment of a tissue penetrating device and/or an analyte detecting meter with equilibrium based measurement system with multiple channels will now be described. In one embodiment, each penetrating member 1070 is housed in a channel, as illustrated in Figure 108. A multi-arm structure as seen in Figure 109 is positioned adjacent to the channel housing the penetrating member. An equilibrium based measurement is utilized for analyte determination. In one embodiment, the chemistries of analyte detecting members, are separated in a channel in order to ease manufacturing challenges.

By way of illustration, and without limitation, glucose oxidase can be in one channel and Ru in an adjacent one. Oxygen is depleted from the glucose oxidase and the Ru then senses the depletion of the oxygen in the body fluid. It will be appreciated that this equilibrium based measurement method and system can be used for any number of different chemistries and analytes.

In a still further embodiment of the present invention, a tissue penetrating device and/or an analyte detecting meter with spectral encoding of well positions will now be described. In this embodiment of the present invention, one or more detectors or imagers are provided. In one embodiment, the detector is a plurality of discrete detectors.

Spectral encoding may be used in one embodiment of the invention to spectrally slice the fluorescence spectrum of multiple wells. Imaging homogenization may be used, along with complementary spectral filtering in the filter plane, to separate out the light from the wells. This makes the image position insensitive to the well positions. A processor in the device 1000 may include logic for handling the spectral encoding. A spectrofluorometer may be used to detect the signal. In one embodiment, the well may contain a plurality of beads and it may be possible to spectrally encode the beads used in wells.

In a still further embodiment of the present invention, a tissue penetrating device and/or an analyte detecting meter with cylindrical optics to reduce image position sensitivity will now be described.

In one embodiment of the present invention, cylindrical optics are included. The cylindrical optics provide an afocal imaging system such that a point image from a well associated with a sensor is transformed to a line image. The line image overfills a linear detector array in a direction that is perpendicular to a scan of the array. This desensitizes an image position relative to a radial position of the well. In some embodiments, the

cylindrical optics have a longitudinal axis orthogonal to the direction of the light reflected from the object. In other embodiments, the cylindrical optics have their longitudinal axis substantially parallel to the light from the object.

In a still further embodiment of the present invention, a tissue penetrating device and/or an analyte detecting meter with detent placements will now be described. Detents may be positioned close to the penetrating members and/or the wells. The detents, or other equivalent structures, are utilized to reduce effects of position tolerances that can occur during manufacturing and alignment. These effects can be the direct result of maintaining mechanical tolerances. The detents can be utilized to hold the penetrating members in a plane of various optical components of the system.

In a still further embodiment of the present invention, a tissue penetrating device and/or an analyte detecting meter with CMOS imager for multiple well sensors will now be described.

In one embodiment, an image integrated circuit is utilized with a plurality of disconnected areas. One or more CMOS imagers are utilized. This enables circuitry to be positioned around each image patch of the sensor wells. Parallel read-outs are produced. This embodiment also provides more correction of imperfections in the wells, including but not limited to well off-set. Issues relating to use of a regular array of pixels can be resolved.

In a still further embodiment of the present invention, a tissue penetrating device and/or an analyte detecting meter with corrected importations in imager arrays for fluorescence lifetime measurement will now be described.

In one embodiment of the present invention, the performance of imager arrays, is improved for fluorescence lifetime or other optical measurements. Means are provided for correcting, or adjusting, gains of individual pixels, or groups of pixels, in an imager array. The offsets can be corrected by injecting correction signals, into suitable correction circuits, using DAC's. An importation process is utilized to compute digital conversion values that are input into the DAC's. Suitable importation processes include, but are not limited, measuring offsets with no incident light, measuring gains using a fixed incident light level, and the like.

Referring now to Figure 110, one embodiment of a tissue penetrating device and/or an analyte detecting meter with an optical imager array will now be described.

In one embodiment, the performance and multi-functionality of an optical imager array associated with the wells is improved. In one embodiment, the optical imager array is a CMOS. The optical imager can include one or more groups of pixels. By way of illustration, and without limitation, a mixture of pixel sizes and geometries for a task group is utilized. This reduces, and can minimize, the number of pixels and associated circuitry, and/or optimize the signal-to-noise ratio (SNR) of different pixels for different optical measurement functions for analytes in response to the analyte detecting members.

It should be understood that a variety of fluorescence lifetime measurement modalities may be used (ie pulse, phase, square wave) with any of the embodiments of the present invention. A CMOS array may have the following advantages:

It can increase the mechanical tolerances in the metering device. One implementation would be that the CMOS chip takes a full frame picture of the illuminated chemical wells, determines which pixels are looking at which wells, then proceeds to readout only the illuminated pixels. Any mechanical movement is compensated for in software. Excitation light over-flooding may be compensated for as provided by various embodiments discussed herein.

In one embodiment, a CMOS array can provide focus compensation (at the expense of collection the same amount of light from more pixels and perhaps reducing the SNR). A CMOS detector, in this nonlimiting example, can decrease cost by using 1 detector instead of 6 (assuming 6 chemical wells). A CMOS detector decreases cost by allowing integration of detectors, pre-amp, and adc on same chip. The CMOS detector can centralize dc offset and gain drift to a single point, allows for automatic adjustment of offset and gain, decreases the cost by allowing other signal processing functions on the same chip.

As a nonlimiting example, a CMOS detector may make it easy to change chemical well geometry, referencing, etc. without redesign of the optical system. This may turn out to be one of the more important advantages of using CMOS arrays. Any change in chemical well geometry with discrete detectors, will require substantial changes in the optics. With sufficient pixel density and count, the addition of more wells, changes in well geometry, or changes in well spacing could be easily handled via software changes to the processor in a device such as but not limited to that of device 1000.

A CMOS detector provides the ability to read encoded data on cartridges such as bar codes. A separate system for reading data encoded into cartridges would be needed if

discrete detectors are used. The CMOS detector also has the ability to determine the start time for the measurement by looking at the fluid front.

The present invention also compensates for disadvantages of known CMOS detectors. In some CMOS detectors, frame rate may be low. Frame rate is the time it takes to sample one image, move the signal from the pixels to ADC, digitize, then process that signal if needed. Each time sample for lifetime imaging may take one frame. Generally, pixel data is read out serially and the frame rate is dominated by this serialization. In one embodiment, fluorescent lifetimes are estimated by taking many frames and averaging the signals. For a given measurement interval (say 1 second), the more frames measured, the better the SNR. In some embodiments, individual detectors may be used where the signals are read out in parallel and the effective frame rate is very fast (limited by the modulation rate of the fluorescence). Fill factor of 40% is typical with current active pixel sensors. In the present invention, 98% is attainable with specialized buried structures and 98% is attainable with linear arrays

In one embodiment of the present invention, fixed pattern noise (FPN) in detectors may be compensated for in the processor. Individual pixels have different gain and dark currents. This creates a noise signal which appears as a fixed pattern in the image. It does not always average out. Some CMOS designs, such as active column sensing, significantly reduce FPN. Compensation for FPN may also be accomplished using processor cycles. This can reduce frame rates. In addition, if the array is used to compensate for mechanical misalignment, then for a given chemical well position, different sets of pixels, with different FPN's will be used to detect signal each time the cartridge is moved.

It should be understood that over-flooding LED illumination may decrease signal levels. Compensation for misalignment may have the imaged area at the chemical well plane larger than the wells or measurement area alone. In order to see all possible positions of those chemical wells within the imaged area, all of the imaged area may be illuminated. That is, the spot of light from the LED would overflow the measurement area. Only a fraction of the illuminating photons would then go towards generating fluorescence.

In some embodiments, the frame rate is one of the primary specifications used in determining a given imaging array's applicability to measuring lifetimes. This is because frame-rate times pixel-count determines the pixel readout rate. The pixel readout rate sets

the sampling rate used to estimate the fluorescent lifetime. Since multiple frames may be averaged to estimate lifetimes, the SNR will increase with increasing frame rate. The maximum frame rate is limited not only by the chip bandwidth, but also the maximum rate one can modulate Ruthenium fluorescence.

5 In one embodiment, to estimate a fluorescence lifetime, several samples or frames of the fluorescent signal may be taken at differing times. This does not include averaging used to achieve a certain SNR. For example, the number of frames required for phase and square wave modes are:

(1) for phase, assuming quadrature sampling = 4 frames per modulation period
 10 (2 minimum, 4 needed to remove dc term)

(2) for square wave modulation = 2 to 4 frames per modulation period (2 minimum, more needed to remove dc term)

(3) Assuming one sample per frame, the Ruthenium lifetime provides a fundamental limit to the frame rate one needs. Minimum Ruthenium lifetimes are
 15 approximately $t = 2$ usec, implying maximum modulation rates f of:

$$\text{phase: } f \cong \frac{1}{2\pi\tau} = 80 \text{ khz}$$

$$\text{square wave: } f \cong \frac{1}{6\tau} = 83 \text{ khz (assuming } 3\tau \text{ to decay)}$$

In one embodiment of the present invention, 10 nanowatts of fluorescence
 20 emission power was seen at the detector plane from a single chemical well of 200 x 200 microns. This gives a fluorescence emission intensity: $I = 250$ milliwatts / meter² (at the detector plane). Optical magnification was equal to 1, actual chemical well dimension was about 100 x 100 micron. The emission wavelength for this embodiment was approximately 650nm. Each frame comprises one component of a multi-component
 25 lifetime determination. For example for phase: one frame for I, then one frame for Q; or for pulse excitation: one frame for the integral of the first half of the fluorescence decay, and one frame for the second half. All SNR estimates are for the *one* of these components (e.g. I or Q, ect.). The SNR for the estimate of τ will be different. See section B. Ruthenium lifetime = 2usec, sample integration time = 2usec, max excitation

modulation rate = 80 KHz (limited by Ru response time). Read noise scales as square root of pixel area (due to KTC noise):

1. Averaging multiple frames improves the SNR by $\sqrt{\text{number of frames}}$
2. $SNR / well = (SNR / pixel) \sqrt{\frac{A_{well}}{A_{pix}}}$

5 where

A_{well} \equiv area of the image of the chemical well at the detector plane

A_{pix} \equiv area of a single pixel

It was determined that source leakage (that is light from the excitation signal directly reaching the detector) was not an issue for square wave or pulse method.

10 Software may allow the detector to be driven in three modes such as but not limited to: pulse, phase, or amplitude. The frame rate, pixel rate, number of pixels, integration time, and sampling parameters for each of the measurement modes is changeable by the user. Timing diagrams for the three modes of operation are shown in Appendix C.

15 In one embodiment of the present invention, a circuit was designed and built which simulates Ruthenium fluorescence. In one embodiment, it can generate fluorescence decay profiles similar to that seen by either pulsed or sinusoidal excitation. For pulse excitation, a TTL input pulse is put through a first order exponential filter which then drives an LED, giving a light output with a first order exponential decay. The

20 lifetime is adjustable from 2 to 5 microseconds. A red 650nm LED is used to simulated Ruthenium emission fluorescence. For sinusoidal excitation, a second input accepts continuous TTL pulse trains of frequency equivalent to a sinusoidal excitation one would use in a phase type system. The output is a sinusoidal emission which is phase shifted by a first order exponential function. The circuit is shown in Appendix D.

25 Referring now to Figure 110, a block diagram of one embodiment of the optical system is shown. In this particular embodiment, it comprise a red LED (650 nm), whose light is passed through a 100 micron pinhole. Light emanating from the pinhole is imaged via an afocal lens arrangement using two achromatic doublets. The space between the lenses was used to temporarily steer the beam for power measurements. Power from the

30 pinhole was adjusted so that its image at the detector plane was approximately 2

nanowatts (peak). The pinhole is imaged onto the linear array with a magnification of 1:1. The array is mounted to an xy stage for fine tuning its position relative to the pinhole image. All beampaths were kept in light tight black anodized 1" diameter tubing (Thor Labs).

- 5 Processing may be done on or off chip. The time slices may be generated to select out the required time samples of the fluorescent signal. These time slices may be taken as fast as possible to maximize SNR. The resultant high bandwidths have two major implications: First, the electronics, both on chip and off chip will require an added level of care and simulation in order to function properly with minimal excess noise impact.
- 10 Second, the power consumption of this device and its associated ADC and signal processing could be significant. This should be kept in mind when designing the battery operated handheld version.

In another embodiment of the present invention, a tissue penetrating device and/or an analyte detecting meter with improved storage stability will now be described. In this

15 embodiment, penetrating members and their associated sample chambers are in a controlled environment during storage. A resealable septum, or other suitable device, is provided for the penetrating members, penetrating members and their associated sample chambers with analyte detecting members. The resealable septum can be utilized with multiple tissue penetrating members, and their associated multiple sample chambers with

20 analyte detecting members. This improves the pre-use shelf-life and post-use storage.

The chemistry of the materials used for fluorescence detection of analytes will now be described.

Referring now to Figure 111, a tissue penetrating device and/or an analyte detecting meter with single step deposition analyte detecting members will now be

25 described. In one embodiment, a single step process is utilized to place the analyte detecting members in each well 1100. This simplifies the manufacturing steps for deposition of the different chemistries that make up the analyte detecting member.

As a nonlimiting example, the analyte detecting member may be a sensor layer of a single material that is deposited in one step. The sensor layer is a combination of

30 everything that is deposited in a well 1100. This is achieved by forming an emulsion of a Ru sensing phase within a group of oxidase sensing materials. This emulsion is then deposited as a single step on the surface of the structure that houses all of the wells. A plurality of separators 1104 may be attached to the substrate 1106 as indicated by arrows

1108 to keep fluid from one area from flowing to wells in another area. In one embodiment, the separators 1104 may be connected to have a hub-and-spoke configuration.

In another embodiment of the present invention, a tissue penetrating device and/or an analyte detecting meter with multi-analyte sensing will now be described. It should be understood that any of the compounds described herein may be adapted for use with a cartridge 500 or with the embodiments shown in Figures 89-96. In this embodiment, the analyte detecting members in the wells detect and/or measure multiple analytes. An emulsion based analyte detecting member is provided. The inside of the analyte detecting member includes an oxygen sensor and is surrounded by an enzyme. In one embodiment, a glucose detecting member can be created with an emulsion of beads. For a multi-analyte sensor, the dispersed elements are segregated so that one bead has one enzyme, and another bead has a different enzyme. In place of the beads, multi-phase emulsions can be utilized.

For other embodiments, the possible embodiments of the emulsion include 1) Use of emulsifiers with liquid silicone/hydrogel system, 2) Use of emulsifiers with x-linked silicone/hydrogel system, 4) Siloxane sol-gel/hydrogel system, and 5) Solid-supported O₂ sensor/hydrogel. Candidate supports include silicas and zeolites. In one embodiment, hydrophile-lipophile balance (HLB) considerations are used to select candidate emulsifiers. Using simple, lab-available mixer, series of emulsions and dispersions varying, relative ratios of silicone/hydrogel, amount of emulsifier or dispersant, technique of addition (e.g. silicone/water pre-emulsion or direct emulsification into hydrogel solution), extent and degree of mixing, etc. are prepared.

The advantages of an emulsion system are its one-step application of the polymer system and an expectation that the increased interfacial area it provides will be desirable to achieve adequate signal sensitivity as the size of the polymer sensor system is progressively reduced. Interestingly, there is a hint that this dispersed configuration might be better than a two-layer configuration. O. S. Wolfbeis, I. Oehme, N. Papkovskaya and I. Klimant, *Biosensors and Bioelectronics*, 15, 69 (2000), provide a little limited data suggesting the dispersed approach gives longer operational stability (longer lifetime of product) than a two-layer approach.

One aspect of the present invention comprises identifying emulsifier candidates. In one embodiment, the desired HLB for polydimethylsiloxane (PDMS) silicone oil is 9-11. Paraffinic mineral oil has a similar required HLB of 10, more polar fluids have higher

required HLBs (e.g. toluene is 15). This similar desired HLB for PDMS and aliphatic hydrocarbons is the reason why conventional hydrocarbon emulsifiers developed for hydrocarbon-in-water emulsions work well for silicone-in-water emulsions. The principal intermolecular interactions between PDMS molecules are the London forces between the methyl groups. The more polar siloxane backbone is shielded by the pendent methyl groups and has minor impact, causing the silicone to behave much like an aliphatic hydrocarbon in this respect. Consequently, it is not necessary to use silicone-based emulsifiers. Although they are available they are more expensive and can be obtained only in a more restricted range of HLBs than organic emulsifiers. The starting point for obtaining good emulsions is to match the required HLB of the oil to the HLB number of the emulsifier. Often two or more emulsifiers with a net average HLB of the required value is better than a single emulsifier. The conventional explanation of this is that the lower HLB component will usually be of smaller size and is likely to depress the interfacial tension more rapidly thereby aiding in emulsion formation. The higher HLB component will be bulkier and can bring steric repulsion factors that contribute to emulsion stability. The likelihood that a variety of low HLB/high HLB combinations will be tried is a good reason to focus on organic emulsifiers first and move to silicone-based emulsifiers only if the research direction requires it.

In one embodiment, TERGITOL TMN series of emulsifiers produced by Union Carbide Corporation (now a part of Dow Chemical) are used. They are the only line of organic emulsifiers specifically marketed as silicone-in-water emulsifiers. They are based on the trimethylnonyl hydrophobe (hence the TMN designation) and the poly(ethylene oxide) (EO) hydrophile. Their structure is $(\text{CH}_3)_3\text{C}(\text{CH}_2)_8(\text{EO})_n$. TMN-6 ($n = 6$) has HLB 11.7. TMN-3 (HLB 8.1) and TMN-10 (HLB 16.1) are also available. Various mixtures will be tried starting with 50/25/25 TMN-6/TMN-3/TMN-10.

The well-known SPANS (sorbitan fatty acid esters) and TWEENS (ethoxylated adducts) are widely used in the pharmaceutical industry and known to be useful in emulsifying silicones, see, for example, German patent DE 19844262, 3/30/00 assigned to Beiersdorf AG or D-Y. Lee, C-N. Jung, K-D. Su, H-K. Choi and Y-H. Park, *Kongop. Hwahak* 6, 1124 (1995). Several companies, including ICI, produce these materials under the SPAN, TWEEN and other trade names (e.g. ICI's ARLACEL). For example, TWEEN 85 is an ethoxylate sorbitan trioleate with a total of 21 ethylene oxide units and an HLB of 11.0. Many combinations for achieving this value are also possible. A

TWEEN 60/SPAN 60 mixture will be amongst those tried initially. TWEEN 60 is POE(20) sorbitan monostearate with HLB 14.9; SPAN 60 is unethoxylated sorbitan monostearate with HLB 4.7. One attraction of these sorbitan-based emulsifiers is their compatibility with proteins (hence their pharmaceutical use) however, compatibility with the glucose oxidase chemistry might be an issue.

Alkylphenyl ethoxylates, e.g. the NONOXYNOLS based on nonylphenoxy(EO)_n and OCTOXYNOLS based on octylphenoxy have also been used to stabilize silicone emulsions. For example, a mixture of OCTOXYNOL-3 (n=3), HLB 8, and OCTOXYNOL-13 (n = 13) is used in a Dow Corning patent, JP 61230734, 10/15/86. See also B. A. Saadevandi and J. L. Zakin, *Chem. Eng. Comm.* 156, 227 (1997) where NONOXYNOL-6 of HLB 10.8 is used, supplied by Rhodia under the trade name IGEPAL CO-530.30.

Note also that there are a number of silicone-polyether surfactants with HLBs in the 9 to 11 range. These include materials from GE, Th. Goldschmidt AG, and Dow Corning. However, most silicone-based emulsifiers are of much lower HLB and formulated as water-in-oil (inverse) emulsifiers and specialty wetting agents.

Based on the above, HEMA partitioned into trimethylsilylmethylmethacrylate in all cases within the examined range of water content. HEMA also partitioned into water in all combinations with acryloxypropyltris- (trimethylsiloxy)silane within the examined range of water content. However, this silane does not dissolve the Ru-complex.

HEMA also partitioned into water in all combinations with methacryloxypropyl-pentamethyldisiloxane and within the examined range of water content. However, trace amount of HEMA were also found in the siloxane monomer phase, and this amount did not seem to be water/HEMA content dependent. Importantly, Ru-complex is soluble in this disiloxane and for this reason it is presently the monomer of choice for emulsification studies with HEMA and water.

Additionally, seven different silicon-containing hydrophobic monomers and some dual mixtures of these monomers were evaluated for Ru complex solubility, ability to form emulsions, emulsion stability, and sensor properties of the resulting emulsions. Several different preparative procedures were developed (Figure 1) and evaluated and the preferred hydrophilic-lipophilic balance (HLB) for each monomer and/or monomer mixture was determined (see Figure 2). Emulsions containing UV sensitive initiators, Ru complex sensor and glucose oxidase (GOX) were made with hydroxyethyl methacrylate

(HEMA) and poly-(ethylene glycol) methacrylate/poly(ethylene glycol) dimethacrylate (PEGMA/PEGDA). Over a dozen of these emulsions had stabilities ranging from 24 hours to several days. An example of a typical stable emulsion is shown in Figure 3.

Formulation: Hydrophobic phase: hydrophilic phase = 1:2 (v/v); In hydrophobic phase; Monomer 5: Monomer 1 = 4:1 (w/w); Surfactant: 1 wt. % of total monomers, Tergitol 15-S series (as indicated in the insert) with various HLB values; Excluded: GOX, Ru complex, benzoin ethyl ether (BEE) initiator.

Orange samples: Examples of stable emulsions containing Monomer 5, BEE, Ru complex, PEGDA, PEGMA, water, GOX and emulsifier Tergitol-15-S-15. Milky white samples: examples of separated unstable emulsion (these samples did not contain Ru complex). It should be understood that emulsions based on mixtures of Monomers 5 and 1 have shown improved sensor properties over the layer coating approach

Of the stable emulsions prepared, some of the best combinations of desired properties were obtained from those containing 4:1 (w/w) mixtures of 1,3-bis(3-methacryloxypropyl)tetramethyldisiloxane (Monomer 5) and trimethylsilylmethylmethacrylate (Monomer 1) in the hydrophobic phase. These emulsions were prepared with various GOX concentrations (ranging from 1 to 21 mg/mL) and phase ratios (ranging from 1:1.5 to 1:4 hydrophobic: hydrophilic phase). Test results indicated the following improvements over the layered coating approach, including but not limited to, better reproducibility from well to well, significantly higher fluorescence intensity that may enable size reduction of the 2nd generation sensors to only 1/20 of the size of the 1st generation, improved mechanical robustness of emulsion coatings compared to hydrogel layers which significantly reduces or completely avoids leakage of GOX; and high GOX formulations showed very fast responses (less than 10 seconds).

One favorable emulsion formulation is an emulsion containing 1:2 (v/v) hydrophobic/hydrophilic phases, 4:1 (w/w) Monomer 5: Monomer 1 mixture for the hydrophobic phase and 1 mg/mL GOX content in the hydrophilic phase.

The obtained results confirm that emulsion approach offers better reproducibility, faster responsiveness and a higher signal output than the layer approach, but the dynamic range of fluorescence-life-time (FLT) can be improved. It will be possible to overcome this deficiency, which is a property of the hydrophobic monomer(s) used, by utilizing new, tailor-made monomers.

Even emulsions from the most-difficult-to-emulsify Monomer 1 can now be made adequately stable with life-times between 22 and 24 hours. Monomer 1 represented a problem from the beginning of this work: while it has very desirable oxygen quench properties, it is also very difficult to emulsify. This monomer's emulsions, however, can remain stable for at least 22 hours by using the phase inversion emulsification technique. For this reason, the phase inversion approach can be combined with utilization of mixed surfactants with higher and lower HLB values. This will prolong the life-time of Monomer 1 emulsions to as much as 3 days.

It should be understood that in some embodiments, emulsion formulations may be crosslinked. An emulsion curing approach has been developed using benzoin ethyl ether (BEE) a UV sensitive free radical initiator in the hydrophobic phase, and water-soluble (2,2-dimethoxy-2-phenyl acetophenone (Irgacure 651) in the hydrophilic phase. Upon exposure to UV light, these initiators effectively crosslink (cure) emulsions in an adequately short time (minutes).

Some nonlimiting examples of monomers that show better combinations of Ru complex solubility, oxygen quenching, emulsion lifetime stability, and synthetic reproducibility include but are not limited to: 1) End-capping one methacrylate end of Monomer 5 with SiR₃ groups in order to improve its FLT dynamic range (i.e. oxygen quench property) while retaining highly favorable emulsification ability:

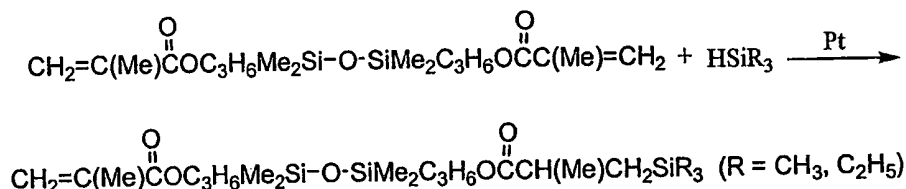

2) preparing an analog of Monomer 1, such as CH₂=CMeCOOCH(SiMe₃)₂ to improve emulsification ability while retaining good oxygen quench properties of Monomer 1:

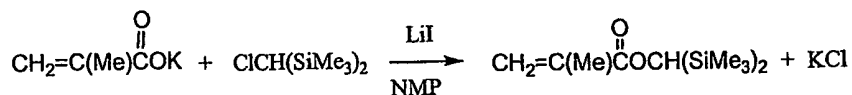

While remaining within the realm of micro-emulsions, the hydrophilic to hydrophobic phase ratio can be increased while retaining very good film robustness even without chemical crosslinking of the phases. This can be achieved by utilizing hydrophilic-hydrophobic block copolymers where mechanical integrity is provided by physical crosslinks between the constitutive blocks resulting from their microphase separation. Appropriate selection of the respective blocks may provide systems that can successfully contain well above 80 % (w) water.

In one embodiment of the present invention, a tissue penetrating device and/or an analyte detecting meter with high sensitivity optical biosensor will now be described.

In one embodiment of the present invention, the natural pyrroloquinoline quinone (PQQ) containing enzyme is isolated from, by way of example, *Acinetobacter calcoaceticus* or preferably the more stable form obtained by cloning into *Esherichia coli*, and is used in conjunction with an autooxidisable electron acceptor. Suitable autooxidisable electron acceptors include but are not limited to phenazine methosulphate (PMS) or phenazine ethosulphate (PES). The combination produces a biochemical system which consumes oxygen in the presence of glucose. This is converted into the analyte detecting member by combining the system with an optical oxygen sensor that is based on fluorescence. The advantage is much higher turnover than alternatives, including but not limited to glucose oxidase (approximately 100 fold), and lower molecular weight. This facilitates smaller sensing areas in a miniaturized array type of device with higher sensitivity at low concentrations of glucose. In another embodiment, sensitive is further enhanced by adding a second enzyme, such as glucose oxidase, to recycle the products of GDH.

The present invention provides an analyte detecting member, that includes PQQ GDF or other PQQ enzymes in combination with an electron acceptor, which readily reacts with oxygen, immobilized in the vicinity of an optical (fluorescence-based) oxygen sensing system to form an optical biosensor where the PQQ enzyme's substrate is the analyte.

In one embodiment of the present invention, a method of creating virtual multi-sensors for a tissue penetrating system will now be described.

In one embodiment of the present invention, a single analyte detecting member is utilized. The chemistry is varied within each analyte detecting member. In one embodiment, a gradient is utilized for each analyte detecting member in a well. A

continual gradient is created across the analyte detecting member, which increases the dynamic range of the analyte detecting member. By way of illustration, and without limitation, two separate drops of different concentrations are deposited into a well. As they diffuse, a gradient is created. In another embodiment, a gel is deposited in a well. A solution is then deposited, with the gel creating the gradient.

In yet another embodiment of the present invention, a method of manufacturing analyte detecting members of a tissue penetrating system will now be described.

In one embodiment, a platform is provided with multiple micro-channels. The platform is positioned above and in contact with the structure that contains the wells which will house the analyte detecting member. A liquid form of chemistry, to be immobilized in the wells, is introduced from the micro-channels into the wells. The platform is then removed. The top of the wells is scraped away, in order to level the amount of analyte detecting member in each well.

In one embodiment of the present invention, a method of sterilizing penetrating members of a tissue penetrating system will now be described.

In one embodiment the penetrating members and the analyte detecting members in the wells are sterilized at the same time. Gamma is used in combination with chemical treatments. In another embodiment, chemical treatments are used with the gamma. Examples of chemical treatments include but are not limited to glutaraldehyde, alcohol, peroxide, and the like.

Referring now to Figure 112, a tissue penetrating device and/or an analyte detecting meter with solid microbeads 1120 in analyte detecting members will now be described.

In one embodiment, analyte detecting member is in the form of a micro-bead. The use of micro-beads eases manufacturing challenges. By way of illustration, and without limitation, a Ru bead can be coated with glucose oxidase. The handling of the chemistries is simplified to minimize wetting issues that can occur with the wells 1122. Use of the micro-beads also removes the need for highly controlled volume deposition when the analyte detecting member is integrated with the wells.

Referring now to Figure 113, one embodiment of a method for manufacturing micro-array analyte detecting members will now be described. In one embodiment of the present invention, a process is provided for manufacturing an analyte detecting member array with a plurality of analyte detecting members, analyte detecting members. Each

analyte detecting member can assess different parameters of interest and can require a plurality of chemistry layers. It should be understood that these method steps may be adapted for use in manufacturing a disc-shaped cartridge 500 or any of the cartridges described herein.

5 As seen in Figure 113, with one embodiment of the method of the present invention, precise deposition of chemistries onto a reaction platform is not required. With the present invention, the method entails three major steps: (1) the manufacturing of reaction platform components that include channels and wells; (2) the deposition of analyte detecting member chemistries in a liquid phase; and (3) the assembly of platform
10 components. These steps are distinct to minimize manufacturing complexity; e.g., the platform components can be manufactured at one location and then brought to a different location for the chemistry deposition step, with minimal transit between locations.

 The reaction platform components may be designed in a manner that allows the analyte detecting member chemistries to be deposited in excess onto certain platform
15 components. Specifically at Step 1, certain platform components include wells 1130, as well as potentially "inverse wells" and holes that expose features of other platform components that are layered on top of these platform components. Other platform components include channels, as well as potentially holes that when aligned with the inverse wells of other platform components effectively become wells themselves.
20 Emulsion or other material are deposited in Step 2. The wells and effective wells created from inverse wells are designed so that that platform material between the analyte detecting member and the detector may be of the same thickness. The method of the present invention desires that the detector have a depth of field that is adequate for the difference in distance between the wells and the effective wells created from the inverse
25 wells. The analyte detecting member chemistry that does not rest in the wells is scraped away from the platform at Step 3. The analyte detecting member chemistry is then set at Step 4, resulting in a solid or semi-solid phase. Step 5 shows that a top layer may be added to provide microfluidics to guide fluid to the wells 1130.

 Referring now to Figure 114, if the analyte detecting member chemistry desires
30 the deposition of multiple layers of chemistries, subsequent layers can be deposited on the same platform components using the same scraping method if the earlier analyte detecting member chemistries volume becomes adequately reduced during the setting process as seen in Steps 6 and 7. Analyte detecting members sometimes desires layers of

chemistries to organize certain chemistries into appropriate environment, such as hydrophilic environment for missing a liquid sample with certain chemistries and a hydrophobic environment for separating molecules in a gas phase from a liquid sample. Alternatively, another platform component may be assembled on top of the platform component onto which the earlier analyte detecting member chemistry had been
5 deposited. This new platform component will have holes positioned such that when it is assembled with the earlier platform it effectively extends the depth of the wells, and the next layer of chemistries may therefore be deposited into the newly extended wells using the scraping method.

10 Referring now to Figure 115, if it is desired to have analyte detecting members in an array that differ in their chemistries, all the analyte detecting members of one kind can be deposited onto a single platform component using the scraping method, and all of the analyte detecting members of other kinds can be deposited onto other platform components also using the scraping methods. Analyte detecting members comprised of
15 different chemistries may be useful to calibrate other analyte detecting members, to assess the presence of substances that are known to interfere with other chemistries, and/or to have analyte detecting members that are tuned to specific ranges of concentration of a particular analyte. These platform components may be assembled adjacent to one another or on top of one another by lining up the wells in the upper platform components with
20 holes in the lower components. Figure 115 show the steps of one method for manufacturing multiple wells 1150 and 1152 on multiple levels. Microfluidic channels 1154 and 1156 may be formed in the layers to guide fluid the associated wells 1150 and 1152.

In another embodiment of the present invention, improved emulsion systems are
25 described. One problems imagined was a possible difficulty with water loss from the continuous hydrophilic phase. In one embodiment, a block copolymer of hydrophobic and hydrophilic polymers such as polydimethylsiloxane (PDMS) and poly(ethylene oxide) (PEO) may be used. The technical field relates to block copolymers. The idea is based on the common, mutual insolubility of different polymers. If covalently bonded
30 together they phase separate into domains. If an ABA type polymer or $(AB)_n$ polymer is used where A is the hydrophobic PDMS chain and B is the hydrophilic PEO chain, one A segment might be in one separated hydrophobic domain and the other A segment might be in another hydrophobic domain or droplet. Thus the hydrophobic domains might be

chained together (held at their ends by covalent bonds with the hydrophilic chains, yet separated and unable to coalesce because of the mutual insolubility of PEO and PDMS chains. In some embodiments, a cross-linking of the PEO chains with each other may be desirable.

5 The present embodiments of the invention envisions block copolymers of hydrophobic, oxygen permeable, Ru complex soluble, polymers such as PDMS with hydrophilic, water-soluble, GOX compatible, polymers such as PEO or polyacrylamide. Additional cross-linking in the hydrophilic phase may be desirable in the presence of water or blood as well.

10 In yet another embodiment of the present invention, improved emulsion systems are provided that make an emulsion particle size sufficiently small that it is geometrically impossible for a GOX molecule to fit inside it. One embodiment of the invention comprises a microemulsion of our preferred hydrophobic and hydrophilic phases.

15 The technical field relates to the field of so-called microemulsions. Ordinary emulsions are, in fact, dispersions on the micro-scale. Microemulsions are dispersions on the nano-scale. Thus a particle size in the 10 to 50 nm range, which is possible for certain microemulsions, could ensure that GOX molecules are excluded (assuming GOX is a typical, large protein of at least 100 nm in size).

20 Microemulsions are thermodynamically stable isotropic solutions containing hydrophobic oils, water and emulsifiers. In one embodiment, our hydrophobic oil is a silicone acrylate and contains Ru complex. Our water contains GOX and hydrogel materials. Nothing is known about how these extra additives will affect microemulsifiability. Several structural types of microemulsion are possible: nanodroplets, cylindrical structure, and bicontinuous. I suspect the nanodroplet type would be best for
25 us as it minimizes the interfacial area which will already be very large (minimum area means minimum possibility of Brownian motion fluctuations causing GOX/Ru complex collisions and interaction). Certainly the bicontinuous arrangement where the two phases form interpenetrating networks separated by a layer of emulsifier would be the least
30 desirable as it seems more a recipe for keeping the phases adjacent to each other than keeping them apart).

Phase diagrams were constructed at various compositions of emulsifier surfactant, hydrophilic phase and hydrophobic phase. Since much smaller dispersion sizes require much greater amounts of emulsifier, it is desirable to have an emulsifier concentration at

least 10X higher than the 1-2% region currently utilized for our conventional, macroemulsions. Compositions in the 20 to 45% emulsifier region may be prepared. The one property of microemulsions that we can most easily exploit is their transparency which results from their particle size being significantly less than the wavelength of light. Thus it is possible to make a variety of compositions and map out the phase diagram area between transparency and opaqueness. Microemulsions are thermodynamically stable and should not separate into two phases at all. Monitoring of this type of stability as we already do for our conventional emulsions will also be a useful indicator.

Referring now to Figure 117, a still further embodiment of the present invention shows a disc-shaped cartridge 1170 and an analyte detecting member cartridge 1172. The cartridge 1172 may have electrochemical detecting members or optical-based detecting members. The members may be on the top side or the bottom side of the cartridge 1172. In one embodiment, a user may lance themselves via a penetrating member from the cartridge 1170. A user may then place the blood onto the detecting member on cartridge 1172. Both cartridge may fit into a device substantially similar to that of device 1000.

With any of the embodiments herein, fluid channels leading to the analyte detecting members may be configured to hold at least about 1.5 μl , 1.4 μl , 1.3 μl , 1.2 μl , 1.1 μl , 1.0 μl , 0.9 μl , 0.8 μl , 0.7 μl , 0.6 μl , 0.5 μl , 0.4 μl , 0.3 μl , 0.2 μl , 0.1 μl , 0.05 μl , or 0.01 μl . As another nonlimiting example, the fluid channels may also be viewed as holding no more than about 1.5 μl , 1.4 μl , 1.3 μl , 1.2 μl , 1.1 μl , 1.0 μl , 0.9 μl , 0.8 μl , 0.7 μl , 0.6 μl , 0.5 μl , 0.4 μl , 0.3 μl , 0.2 μl , 0.1 μl , 0.05 μl , or 0.01 μl , prior to the fluid entering the area 1130. In a still further embodiment, the chamber with the analyte detecting member may hold about 1.5 μl , 1.4 μl , 1.3 μl , 1.2 μl , 1.1 μl , 1.0 μl , 0.9 μl , 0.8 μl , 0.7 μl , 0.6 μl , 0.5 μl , 0.4 μl , 0.3 μl , 0.2 μl , 0.1 μl , 0.05 μl , or 0.01 μl . In some embodiments, the area 1130 is designed to hold a volume slightly less than the amount of that can be held in the channel prior to the fluid reaching the chamber.

As a nonlimiting example, the analyte detecting member used in the present embodiment can provide its analysis using no more than about 1.0 μl , 0.9 μl , 0.8 μl , 0.7 μl , 0.6 μl , 0.5 μl , 0.4 μl , 0.3 μl , 0.2 μl , 0.1 μl , 0.05 μl , or 0.01 μl of fluid. In some embodiments, the amount of fluid used by all analyte members associated with each sample chamber 1150 can provide its analysis using no more than about 1.0 μl , 0.9 μl , 0.8 μl , 0.7 μl , 0.6 μl , 0.5 μl , 0.4 μl , 0.3 μl , 0.2 μl , 0.1 μl , 0.05 μl , or 0.01 μl of fluid.

While the invention has been described and illustrated with reference to certain particular embodiments thereof, those skilled in the art will appreciate that various adaptations, changes, modifications, substitutions, deletions, or additions of procedures and protocols may be made without departing from the spirit and scope of the invention.

5 For example, with any of the above embodiments, the location of the penetrating member drive device may be varied, relative to the penetrating members or the cartridge. With any of the above embodiments, the penetrating member tips may be uncovered during actuation (i.e. penetrating members do not pierce the penetrating member enclosure or protective foil during launch). With any of the above embodiments, the penetrating

10 members may be a bare penetrating member during launch. With any of the above embodiments, the penetrating members may be bare penetrating members prior to launch as this may allow for significantly tighter densities of penetrating members. In some embodiments, the penetrating members may be bent, curved, textured, shaped, or otherwise treated at a proximal end or area to facilitate handling by an actuator. The

15 penetrating member may be configured to have a notch or groove to facilitate coupling to a gripper. The notch or groove may be formed along an elongate portion of the penetrating member. With any of the above embodiments, the cavity may be on the bottom or the top of the cartridge, with the gripper on the other side. In some

20 embodiments, analyte detecting members may be printed on the top, bottom, or side of the cavities. The front end of the cartridge maybe in contact with a user during lancing. The same driver may be used for advancing and retraction of the penetrating member. The penetrating member may have a diameters and length suitable for obtaining the blood volumes described herein. The penetrating member driver may also be in substantially the same plane as the cartridge. The driver may use a through hole or other opening to

25 engage a proximal end of a penetrating member to actuate the penetrating member along a path into and out of the tissue.

Any of the features described in this application or any reference disclosed herein may be adapted for use with any embodiment of the present invention. For example, the devices of the present invention may also be combined for use with injection penetrating

30 members or needles as described in commonly assigned, copending U.S. Patent Application Ser. No. 10/127,395 (Attorney Docket No. 38187-2551) filed April 19, 2002. An analyte detecting member to detect the presence of foil may also be included in the lancing apparatus. For example, if a cavity has been used before, the foil or sterility

barrier will be punched. The analyte detecting member can detect if the cavity is fresh or not based on the status of the barrier. It should be understood that in optional embodiments, the sterility barrier may be designed to pierce a sterility barrier of thickness that does not dull a tip of the penetrating member. The lancing apparatus may also use improved drive mechanisms. For example, a solenoid force generator may be improved to try to increase the amount of force the solenoid can generate for a given current. A solenoid for use with the present invention may have five coils and in the present embodiment the slug is roughly the size of two coils. One change is to increase the thickness of the outer metal shell or windings surround the coils. By increasing the thickness, the flux will also be increased. The slug may be split; two smaller slugs may also be used and offset by $\frac{1}{2}$ of a coil pitch. This allows more slugs to be approaching a coil where it could be accelerated. This creates more events where a slug is approaching a coil, creating a more efficient system.

In another optional alternative embodiment, a gripper in the inner end of the protective cavity may hold the penetrating member during shipment and after use, eliminating the feature of using the foil, protective end, or other part to retain the used penetrating member. Some other advantages of the disclosed embodiments and features of additional embodiments include: same mechanism for transferring the used penetrating members to a storage area; a high number of penetrating members such as but not limited to 25, 50, 75, 100, 500, or more penetrating members may be put on a disk or cartridge; molded body about a lancet becomes unnecessary; manufacturing of multiple penetrating member devices is simplified through the use of cartridges; handling is possible of bare rods metal wires, without any additional structural features, to actuate them into tissue; maintaining extreme (better than 50 micron -lateral- and better than 20 micron vertical) precision in guiding; and storage system for new and used penetrating members, with individual cavities/slots is provided. The housing of the lancing device may also be sized to be ergonomically pleasing. In one embodiment, the device has a width of about 56 mm, a length of about 105 mm and a thickness of about 15 mm. Additionally, some embodiments of the present invention may be used with non-electrical force generators or drive mechanism. For example, the punch device and methods for releasing the penetrating members from sterile enclosures could be adapted for use with spring based launchers. The gripper using a frictional coupling may also be adapted for use with other drive technologies.

Still further optional features may be included with the present invention. For example, with any of the above embodiments, the location of the penetrating member drive device may be varied, relative to the penetrating members or the cartridge. With any of the above embodiments, the penetrating member tips may be uncovered during
5 actuation (i.e. penetrating members do not pierce the penetrating member enclosure or protective foil during launch). The penetrating members may be a bare penetrating member during launch. The same driver may be used for advancing and retraction of the penetrating member. Different analyte detecting members detecting different ranges of glucose concentration, different analytes, or the like may be combined for use with each
10 penetrating member. Non-potentiometric measurement techniques may also be used for analyte detection. For example, direct electron transfer of glucose oxidase molecules adsorbed onto carbon nanotube powder microelectrode may be used to measure glucose levels. In some embodiments, the analyte detecting members may formed to flush with the cartridge so that a "well" is not formed. In some other embodiments, the analyte
15 detecting members may formed to be substantially flush (within 200 microns or 100 microns) with the cartridge surfaces. In all methods, nanoscopic wire growth can be carried out via chemical vapor deposition (CVD) or other vapor deposition. In all of the embodiments of the invention, nanoscopic wires may be nanotubes. Any method useful for depositing a glucose oxidase or other analyte detection material on a nanowire or
20 nanotube may be used with the present invention. Additionally, for some embodiments, any of the cartridge shown above may be configured without any of the penetrating members, so that the cartridge is simply an analyte detecting device. Still further, the indexing of the cartridge may be such that adjacent cavities may not necessarily be used serially or sequentially. As a nonlimiting example, every second cavity may be used
25 sequentially, which means that the cartridge will go through two rotations before every or substantially all of the cavities are used. As another nonlimiting example, a cavity that is 3 cavities away, 4 cavities away, or N cavities away may be the next one used. This may allow for greater separation between cavities containing penetrating members that were just used and a fresh penetrating member to be used next. It should be understood that
30 nanowires may be used with any embodiment of the cartridges described herein. The size and diameters of the radial cartridges described herein may also vary and are not limited to the sizes shown herein.

In some embodiments, in analyzing fluorescence lift times, frame rates in detectors are slow because of the time it takes to serialize many pixels, thus it is desirable to minimize the number of pixels. It may be desirable to select sub-arrays within the chip which have areas of interest (such as a chemical well fluorescent image). Parallel binning
5 may also be desirable as it involves combining the charge on pixels before reading. This lowers the effective number of pixels to be read. These improvements may be achieved through the use of improved processors in a device similar to that of device 1000.

This application cross-references commonly assigned copending U.S. Patent Applications Ser. No.10/323,622(Attorney Docket No. 38187-2606) filed December 18,
10 2002; commonly assigned copending U.S. Patent Applications Ser. No. 10/323/623 (Attorney Docket No. 38187-2607) filed December 18, 2002; and commonly assigned copending U.S. Patent Applications Ser. No. 10/324,053 (Attorney Docket No. 38187-2609) filed December 18, 2002. The present application is related to commonly assigned, co-pending U.S. Patent Application Ser. Nos. US: 10/335,215; 10/335,258; 10/335,099;
15 10/335,219; 10/335,052; 10/335,073; 10/335,220; 10/335,252; 10/335,218; 10/335,211; 10/335,257; 10/335,217; 10/335,212; 10/335,241; 10/335,183; 10/335,082; 10/335,240; 10/335,259; 10/335,182; (Attorney Docket Nos. 38187-2633 through 38187-2652), filed December 31, 2002. This application is related to commonly assigned, copending U.S. Patent Application Ser. No. 10/127,395 (Attorney Docket No. 38187-2551) filed April
20 19, 2002 and commonly assigned, copending U.S. Patent Application Ser. No. 10/237,261 (Attorney Docket No. 38187-2595) filed September 5, 2002. All applications listed above are fully incorporated herein by reference for all purposes. The publications discussed or cited herein are provided solely for their disclosure prior to the filing date of the present application. Nothing herein is to be construed as an admission that the present
25 invention is not entitled to antedate such publication by virtue of prior invention. Further, the dates of publication provided may be different from the actual publication dates which may need to be independently confirmed. All publications mentioned herein are incorporated herein by reference to disclose and describe the structures and/or methods in connection with which the publications are cited.

30 Expected variations or differences in the results are contemplated in accordance with the objects and practices of the present invention. It is intended, therefore, that the invention be defined by the scope of the claims which follow and that such claims be interpreted as broadly as is reasonable.

WHAT IS CLAIMED IS:

1 1. A device for use in a metering device for measuring analyte levels
2 in a sample fluid, said device comprising:
3 a cartridge;
4 a plurality of analyte detecting members mounted on said cartridge, said
5 detecting members using an optical technique to measure analyte levels in said sample
6 fluid.

1 2. The device of claim 1 wherein said cartridge does not include any
2 penetrating members.

1 3. The device of claim 1 wherein said cartridge has a radial disc
2 shape.

1 4. The device of claim 1 wherein said cartridge is sized to fit within
2 said metering device.

1 5. The device of claim 1 wherein the analyte detecting member
2 comprises an emulsion of Ru sensing phase within a group of oxidase sensing materials.

1 6. The device of claim 1 wherein the analyte detecting member
2 comprises an emulsion of Ru sensing phase within a group of oxidase sensing materials
3 deposited in a single step.

1 7. The device of claim 1 wherein the analyte detecting member
2 comprises an emulsion of Ru sensing phase within a group of oxidase sensing materials;
3 the emulsion is one selected from the following group: emulsifiers with liquid
4 silicone/hydrogel system, emulsifiers with x-linked silicone/hydrogel system, emulsifiers
5 of siloxane sol-gel/hydrogel system, TERGITOL TMN series of emulsifiers, and mixtures
6 thereof.

1 8. The device of claim 1 wherein the analyte detecting member
2 comprises an emulsion of Ru sensing phase within a group of oxidase sensing materials;
3 the emulsion having a desired HLB for polydimethylsiloxane (PDMS) silicone oil of 9-
4 11.

1 9. The device of claim 1 wherein the analyte detecting member
2 comprises natural pyroloquiniline quinone (PQQ) and used in conjunction with an
3 autooxidisable electron acceptor.

1 10. The device of claim 1 wherein the analyte detecting member
2 comprises natural pyroloquiniline quinone (PQQ) and used in conjunction with an
3 autooxidisable electron acceptor such as phenazine methosulphate (PMS) or phenazine
4 ethosulphate (PES).

1 11. The device of claim 1 wherein the analyte detecting member
2 comprises a block copolymer of hydrophobic and hydrophilic polymers such as
3 polydimethylsiloxane (PDMS) or poly(ethylene oxide) (PEO).

1 12. The device of claim 1 wherein the analyte detecting member
2 wherein an emulsion particle size is sufficiently small that it is geometrically impossible
3 for a GOX molecule to fit inside it.

1 13. The device of claim 1 wherein the analyte detecting member
2 comprises a block copolymer of hydrophobic and hydrophilic polymers such as
3 polydimethylsiloxane (PDMS) or poly(ethylene oxide) (PEO), wherein PEO chains are
4 cross-linked.

1 14. The device of claim 1 wherein the analyte detecting member
2 comprises an emulsion of Ru sensing phase within a group of oxidase sensing materials,
3 said emulsion containing 1:2 (v/v) hydrophobic/hydrophilic phases, 4:1 (w/w) Monomer
4 5: Monomer 1 mixture for the hydrophobic phase and 1 mg/mL GOX content in the
5 hydrophilic phase.

1 15. The device of claim 1 wherein the cartridge includes a plurality of
2 wells and a central fluid input port for receiving a body fluid with one or more analytes,
3 said plurality of wells coupled to the common input port, each of said wells equidistant to
4 the input port.

1 16. The device of claim 1 wherein the cartridge includes a plurality of
2 wells and a central fluid input port for receiving a body fluid with one or more analytes,

3 said plurality of wells coupled to the common input port, each of said wells equidistant to
4 the input port, said wells positioned to have a star configuration.

1 17. The device of claim 1 wherein said analyte detecting members
2 have different sensitivity ranges enhancing the overall range of sensitivity of an array of
3 such members when used on a single fluid sample.

1 18. The device of claim 1 wherein said analyte detecting members can
2 provide their analysis requiring no more than one of the following volumes: 300, 200,
3 100, 60, 50, 30, 20, 15, 10, and 5 nanoliters.

1 19. The device of claim 1 further comprising a mesh configured fluid
2 spreader positioned over said analyte detecting member.

1 20. The device of claim 1 wherein the cartridge has a higher density of
2 analyte detecting members than 4.53 cubic centimeters divided by 17 per single analyte
3 detecting member.

1 21. The device of claim 1 wherein the cartridge has a higher density of
2 analyte detecting members than 4.53 cubic centimeters divided by 20 per single analyte
3 detecting member.

1 22. The device of claim 1 wherein the cartridge has a higher density of
2 analyte detecting members than 4.53 cubic centimeters divided by 25 per single analyte
3 detecting member.

1 23. The device of claim 1 wherein the cartridge has a higher density of
2 analyte detecting members than 4.53 cubic centimeters divided by 50 per single analyte
3 detecting member.

1 24. A device for use with a body fluid sampling device for extracting
2 bodily fluid from an anatomical feature, said device comprising:
3 a cartridge having a plurality of sample chambers;
4 a plurality of analyte detecting members;
5 wherein at least one of said analyte detecting members forms a portion of
6 one wall of one of said plurality of sample chambers;

7 said analyte detecting members using an optical technique to determine
8 analyte level in the body fluid.

1 25. The device of claim 12 wherein said cartridge further comprises a
2 plurality of penetrating member in cavities on said cartridge.

1 26. A device for use with a body fluid sampling device for extracting
2 bodily fluid from an anatomical feature, said device comprising:
3 a cartridge having a plurality of sample chambers;
4 a plurality of penetrating members each at least partially contained in said
5 cavities of the single cartridge wherein the penetrating members are slidably movable to
6 extend outward from openings on said cartridge to penetrate tissue;
7 a plurality of analyte detecting members;
8 wherein said chamber is positioned substantially adjacent an outer
9 periphery of said cartridge;
10 at least one opening in one of said sample chambers leading fluid along a
11 fluid path towards one of said analyte detecting members.

1 27. The device of claim 19 wherein said fluid path contains a channel
2 sized to hold no more than 1 microliter.

1 28. A method for determining a concentration of an analyte in body
2 fluid, comprising:
3 collecting a sample of body fluid of about 500 nL or less;
4 covering an electrochemical sensor with at least a portion of the sample;
5 determining the concentration of the analyte in the sample using a optical
6 technique.

1 29. A method for manufacturing a device, the method comprising:
2 providing a cartridge having a plurality of wells;
3 depositing an emulsion in the wells;
4 scraping away emulsion from tops of the wells, in order to level the
5 amount of emulsion in each well.

1 30. A device comprising:
2 a plurality of analyte detecting members defining an array;

3 wherein at least two of said members have different sensitivity ranges
4 enhancing the overall range of sensitivity of the array when used on a sample fluid.

1 31. A device comprising:
2 a single cartridge having a plurality of cavities;
3 a plurality of analyte detecting members defining an analyte array;
4 wherein at least two of said sensors have different sensitivity ranges
5 enhancing the overall range of sensitivity of the array when used on a sample fluid;
6 wherein said plurality of cavities each has one analyte array.

1 32. A system comprising:
2 a single cartridge having a plurality of cavities;
3 a plurality of analyte detecting members on the single cartridge;
4 a memory on said device for storing at least one of the following:
5 number of penetrating members used, number of target tissue penetrating
6 events, time and date of the last selected number of target tissue penetrating events, time
7 interval between alarm and target tissue penetrating event, stratum corneum thickness,
8 time of day, energy consumed by a penetrating member driver to drive a penetrating
9 member into the target tissue, depth of penetrating member penetration, velocity of the
10 penetrating member, desired velocity profile, velocity of the penetrating member into the
11 target tissue, velocity of the penetrating member out of the target tissue, dwell time of the
12 penetrating member in the target tissue, a target tissue relaxation parameter, force
13 delivered on the target tissue, dwell time of the penetrating member, battery status,
14 system status, consumed energy, speed profile of the penetrating member as the
15 penetrating member penetrates and advances through the target tissue, a tissue target tissue
16 relaxation parameter, information relative to contact of a penetrating member with target
17 tissue before penetration by the penetrating member, information relative to a change of
18 speed of a penetrating member as it travels in the target tissue, type of electrochemical
19 analyte detecting member used, the kind of test the analyte detecting member will be
20 measuring, information relative to consumed sensors and/or information relative to
21 consumed penetrating members.

1 33. A system comprising:
2 an electric penetrating member driver;
3 a single cartridge having a plurality of cavities;

4 a plurality of penetrating members housed in said cavities and individually
5 movable by said driver to penetrate tissue;
6 a plurality of analyte detecting members;
7 a memory on said device for storing at least one of the following:
8 number of penetrating members used, number of target tissue penetrating
9 events, time and date of the last selected number of target tissue penetrating events, time
10 interval between alarm and target tissue penetrating event, stratum corneum thickness,
11 time of day, energy consumed by a penetrating member driver to drive a penetrating
12 member into the target tissue, depth of penetrating member penetration, velocity of the
13 penetrating member, desired velocity profile, velocity of the penetrating member into the
14 target tissue, velocity of the penetrating member out of the target tissue, dwell time of the
15 penetrating member in the target tissue, a target tissue relaxation parameter, force
16 delivered on the target tissue, dwell time of the penetrating member, battery status,
17 system status, consumed energy, speed profile of the penetrating member as the
18 penetrating member penetrates and advances through the target tissue, a tissue target tissue
19 relaxation parameter, information relative to contact of a penetrating member with target
20 tissue before penetration by the penetrating member, information relative to a change of
21 speed of a penetrating member as it travels in the target tissue, type of electrochemical
22 analyte detecting member used, the kind of test the analyte detecting member will be
23 measuring, information relative to consumed sensors and/or information relative to
24 consumed penetrating members.

1 34. The system of claim 33 further comprising:
2 an optical train for directing reflected light from the analyte detecting
3 member to an optical detector.

1 35. The system of claim 33 further comprising:
2 an optical train for directing reflected light from the analyte detecting
3 member to a CMOS optical detector, said CMOS optical detector is utilized to measure
4 fluorescence lifetimes of the analyte detecting members, wherein a time dependent optical
5 image can be sampled and integrated, on the CMOS by a processor in the system.

1 36. The system of claim 33 further comprising:
2 an optical train for directing reflected light from the analyte detecting
3 member to an optical detector;

4 a grating for displacing an excitation image and a fluorescence image from
5 the analyte detecting member.

1 37. The system of claim 33 further comprising:
2 a process using spectral encoding techniques to spectrally slice the
3 fluorescence spectrum of multiple wells and complementary spectral filtering in the filter
4 plane, to separate out the light from the wells to make image position insensitive to the
5 well positions.

1 38. The system of claim 33 further comprising:
2 a diffuser in the optical train guiding light from the wells to the light
3 detector.

1 39. The system of claim 33 further comprising:
2 a movable viewing lens to correct of misalignment of detector and the
3 object illuminated.

1 40. The system of claim 33 further comprising:
2 a slurry laid over a well of the analyte detecting member;
3 a plurality of luminescent beads of the same color with different non-
4 overlapping lifetimes ranges for their particular analyte, said beads in said slurry.

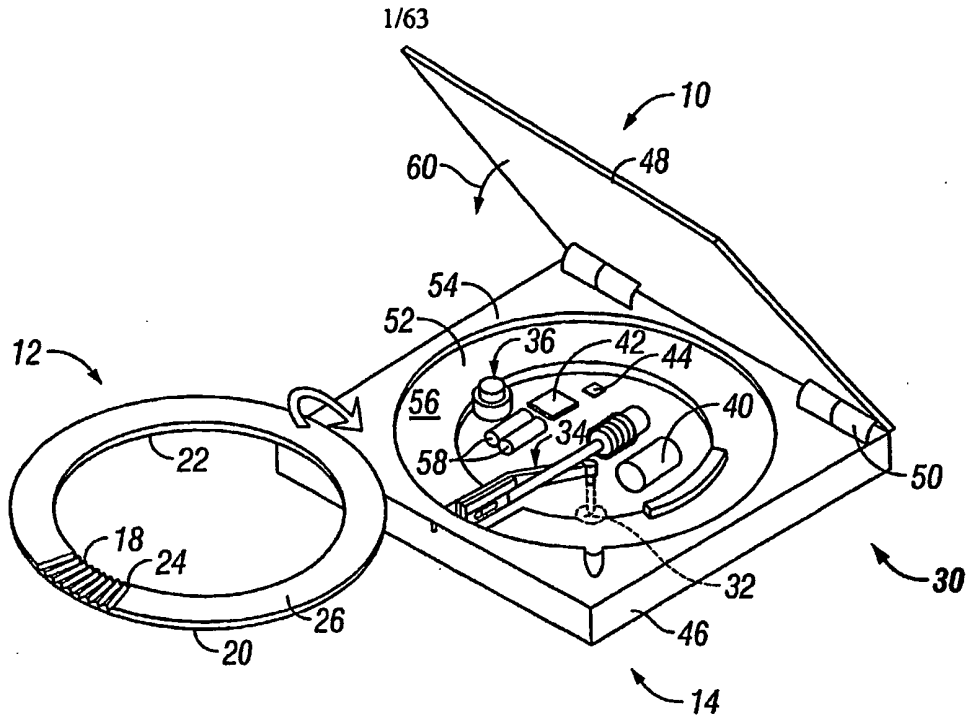

FIG. 1

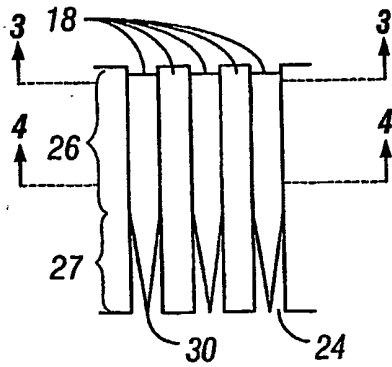

FIG. 2

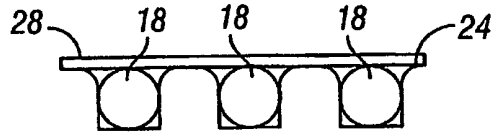

FIG. 3

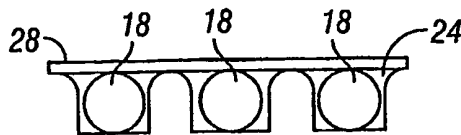

FIG. 4

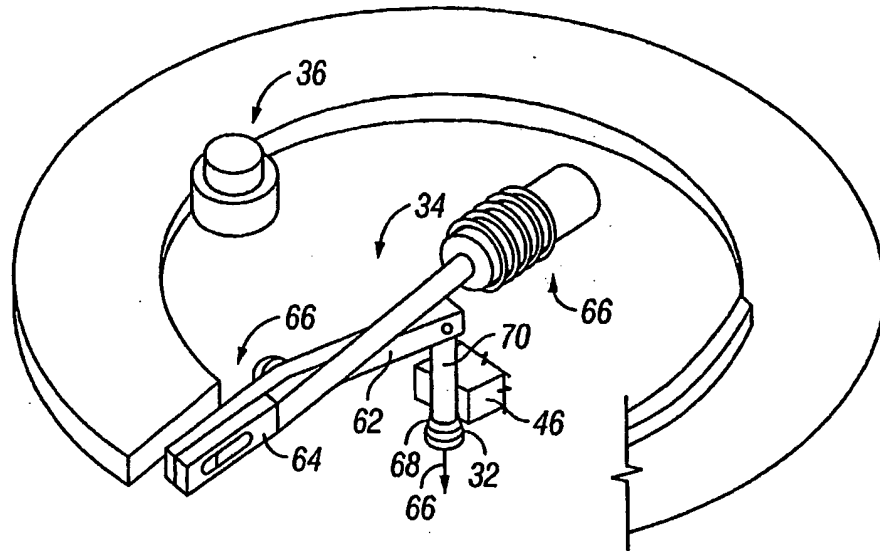

FIG. 5

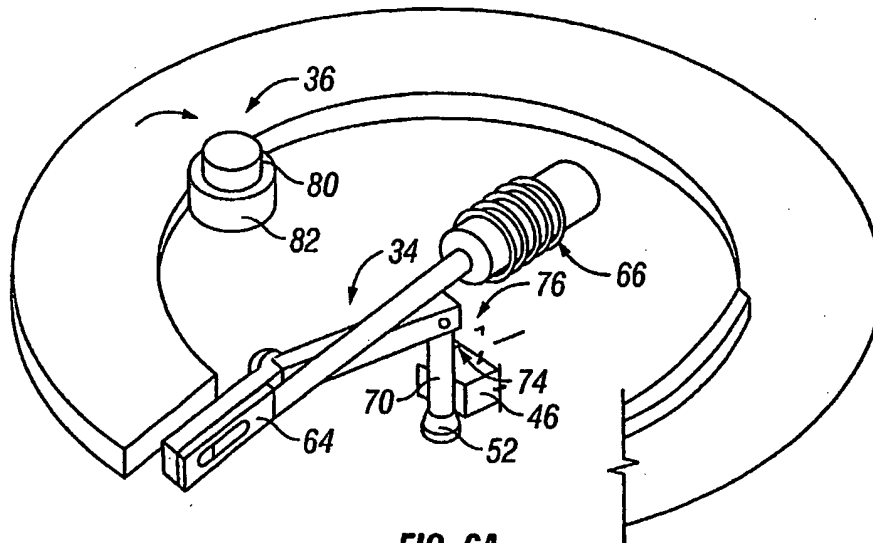

FIG. 6A

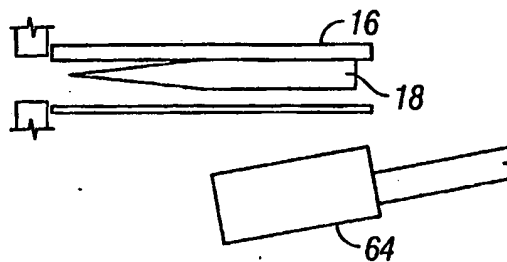

FIG. 6B

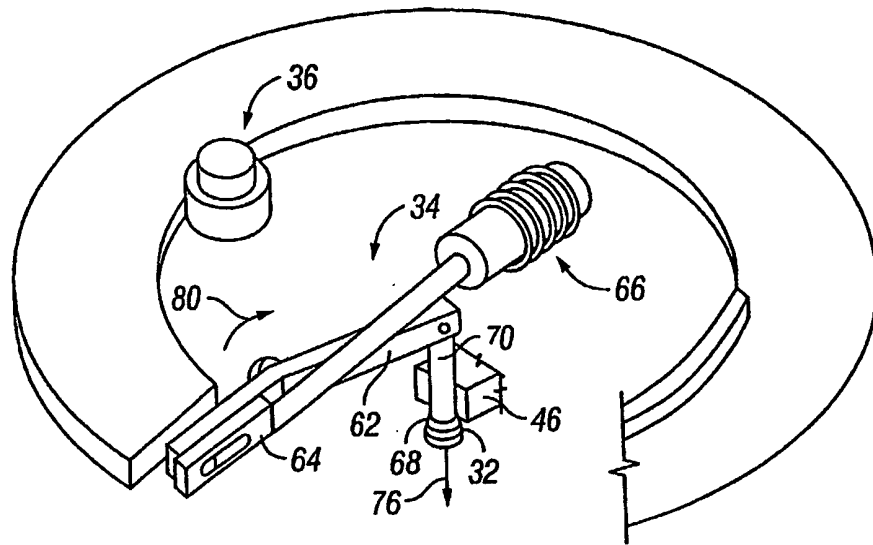

FIG. 7A

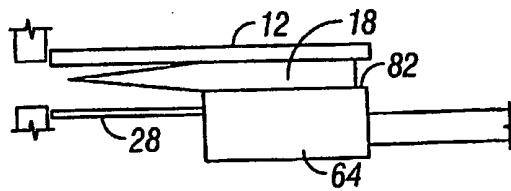

FIG. 7B

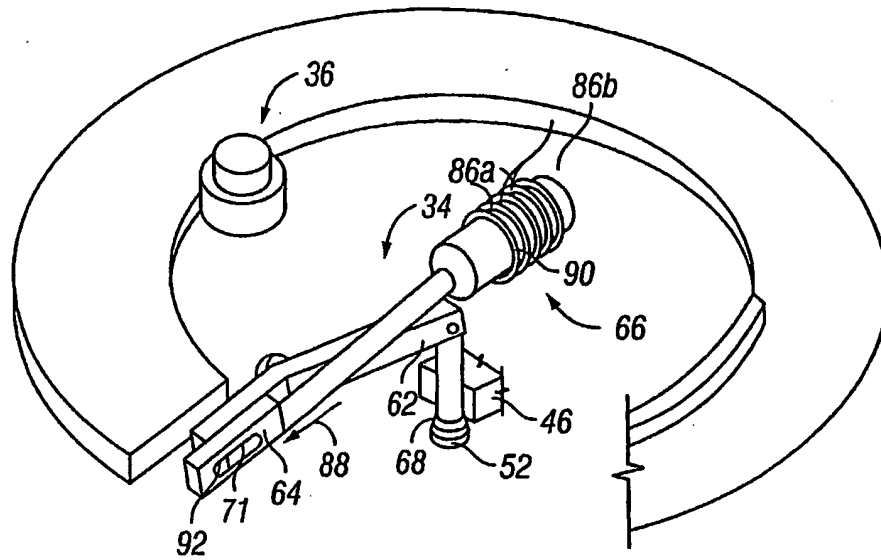

FIG. 8A

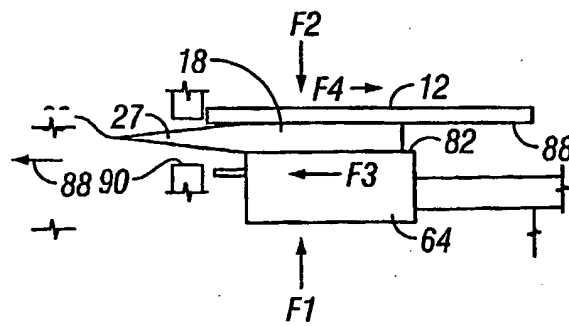

FIG. 8B

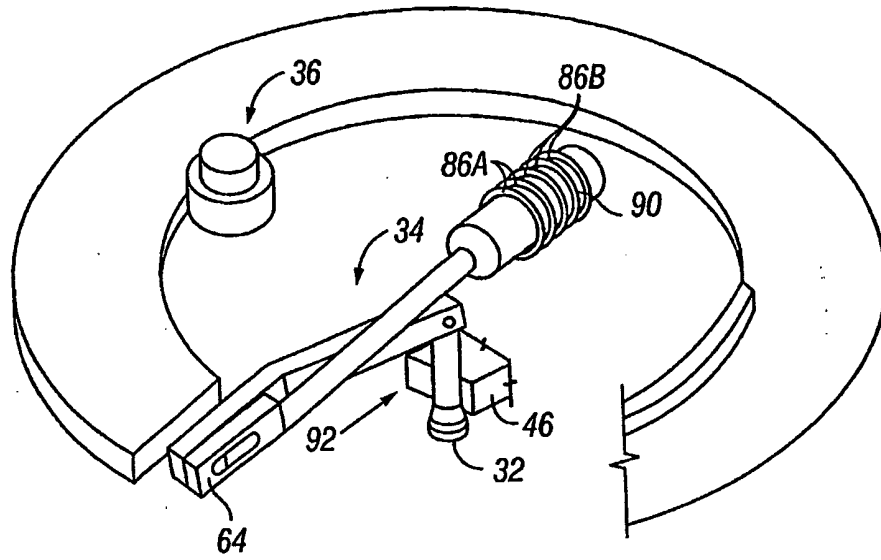

FIG. 9A

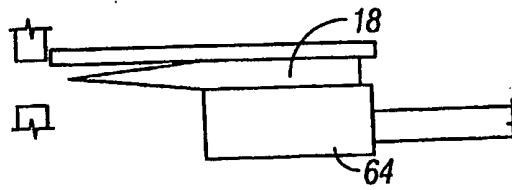

FIG. 9B

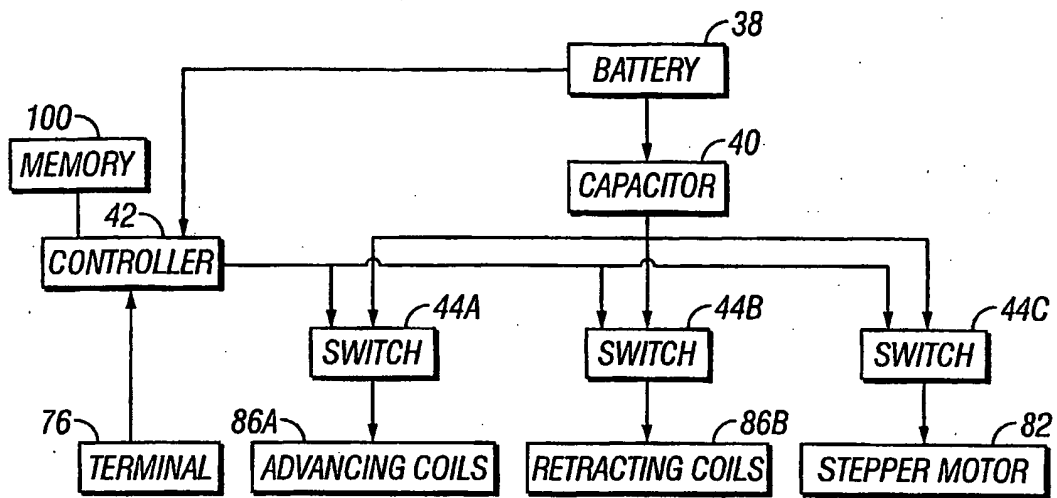

FIG. 10

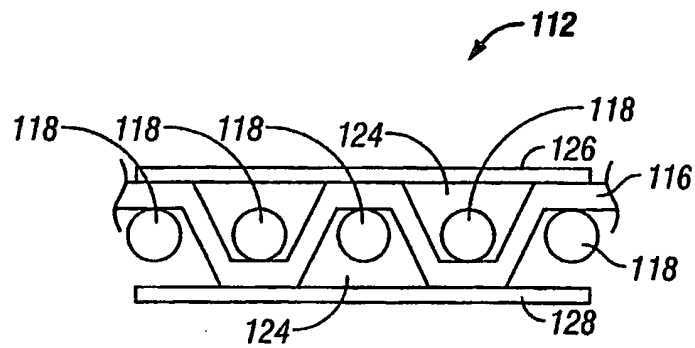

FIG. 11

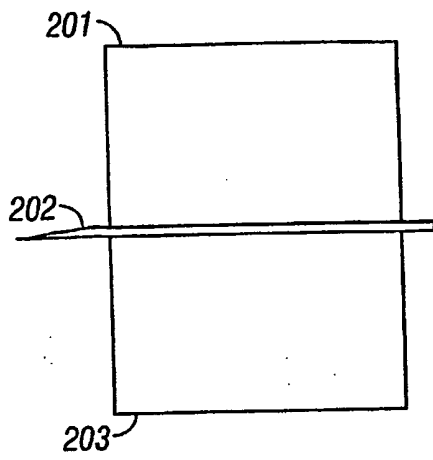

FIG. 12

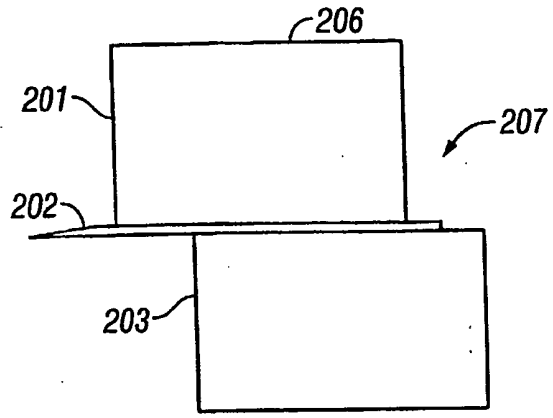

FIG. 13

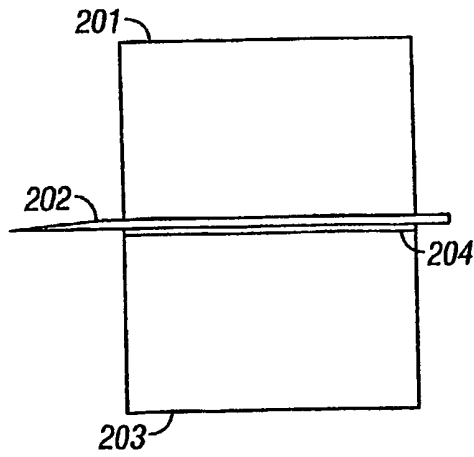

FIG. 14

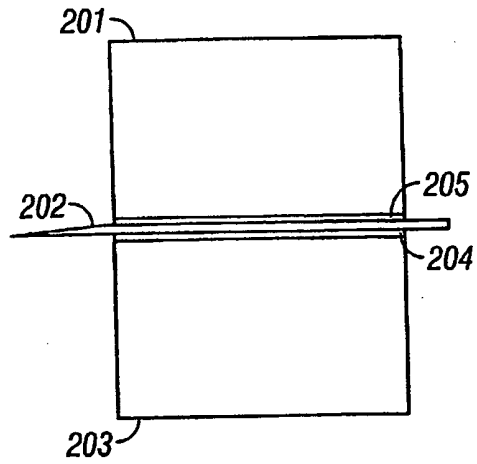

FIG. 15

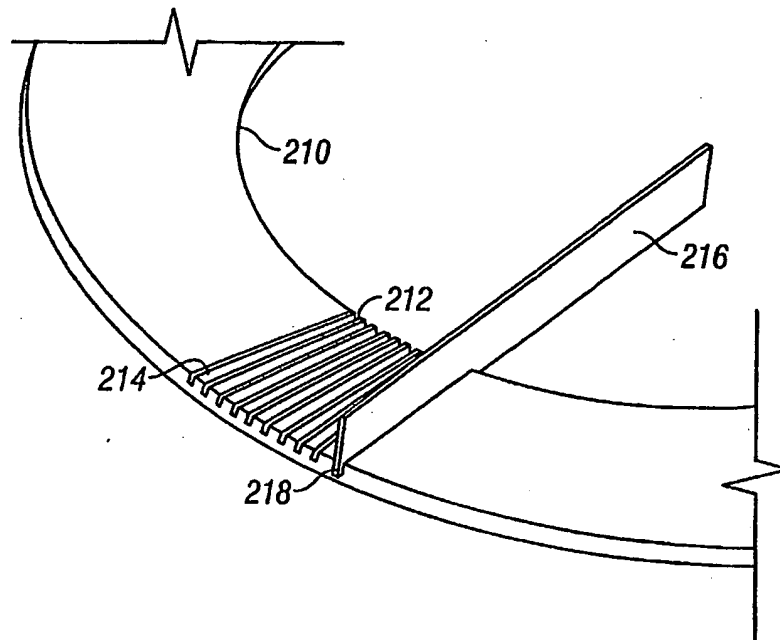

FIG. 16

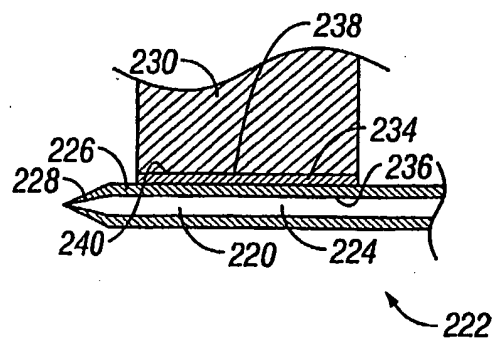

FIG. 17

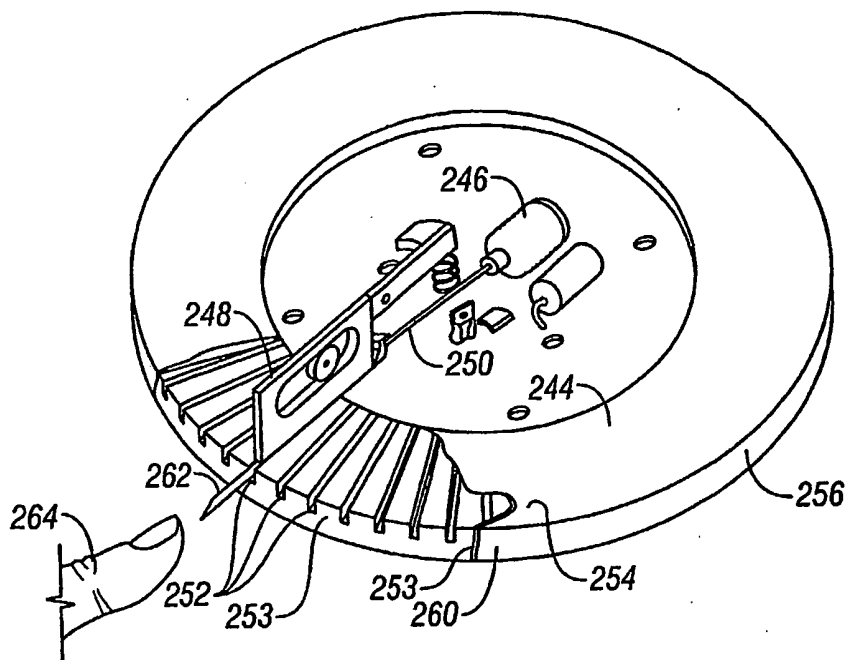

FIG. 18

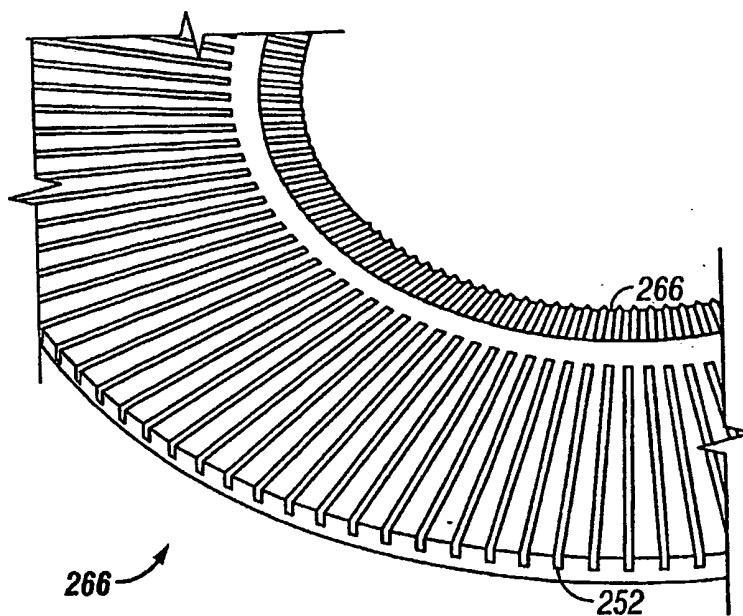

FIG. 19

10/63

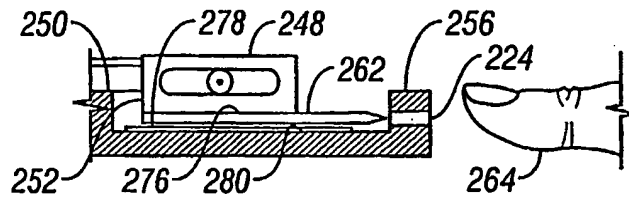

FIG. 20

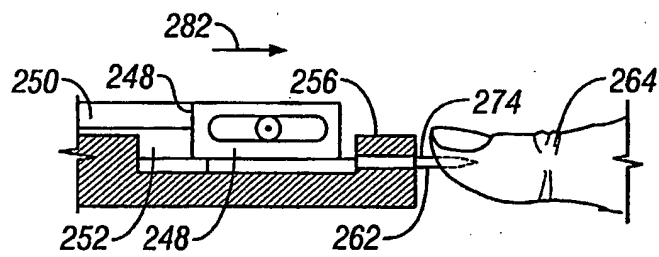

FIG. 21

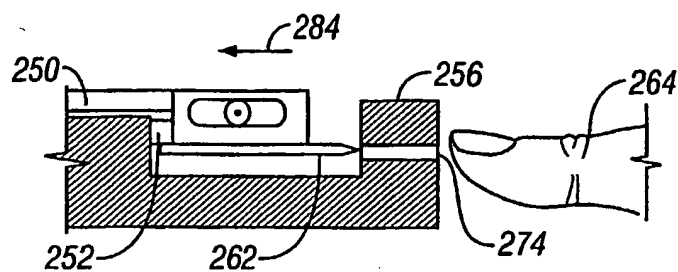

FIG. 22

11/63

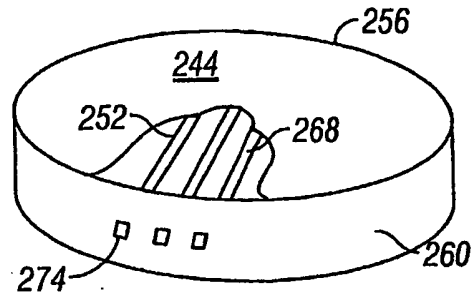

FIG. 23

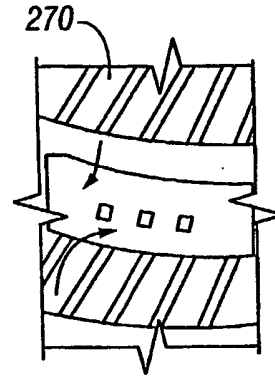

FIG. 24

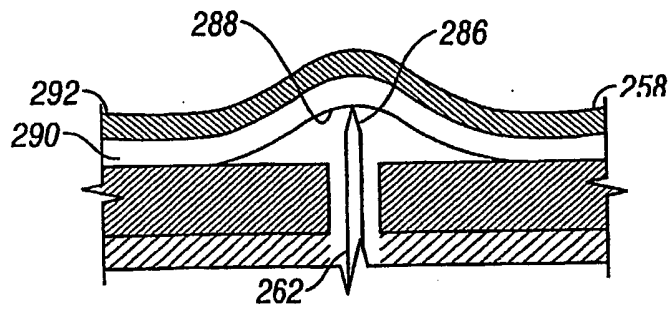

FIG. 25

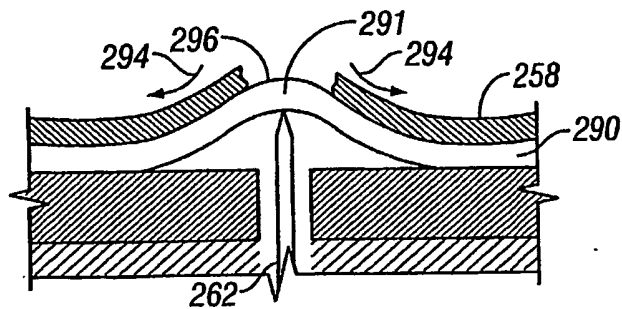

FIG. 26

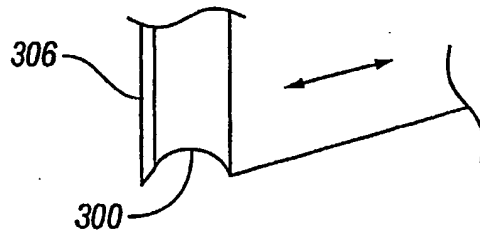

FIG. 27

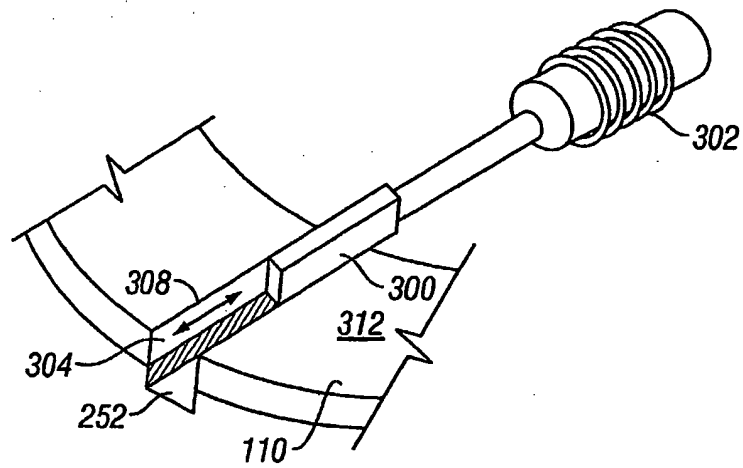

FIG. 28



FIG. 29

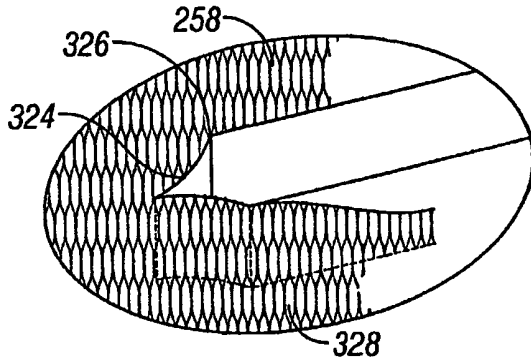

FIG. 30

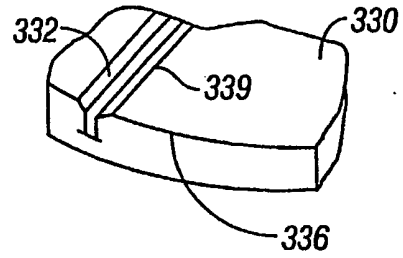

FIG. 31

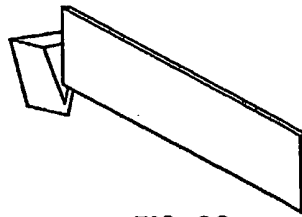

FIG. 32

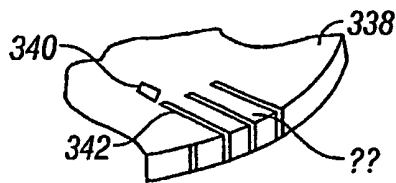

FIG. 33

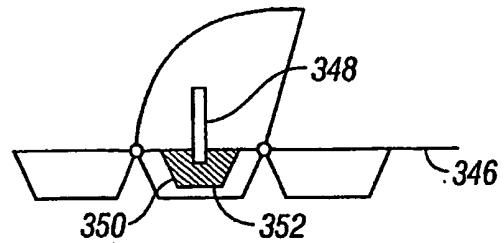

FIG. 34

14/63

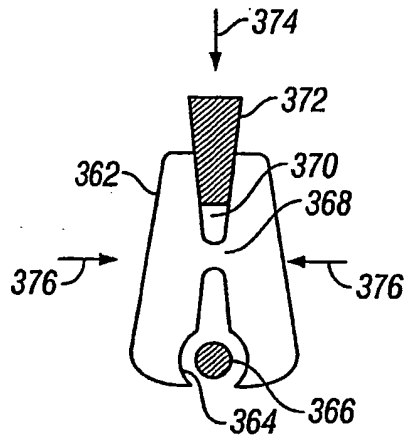

FIG. 35

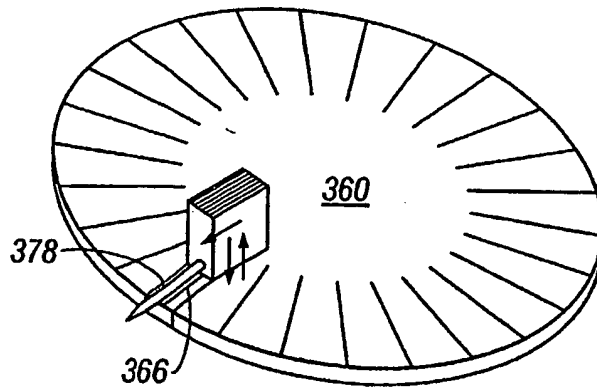

FIG. 36

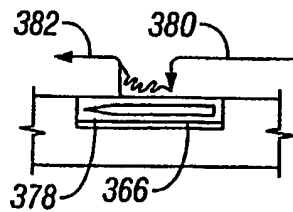

FIG. 37

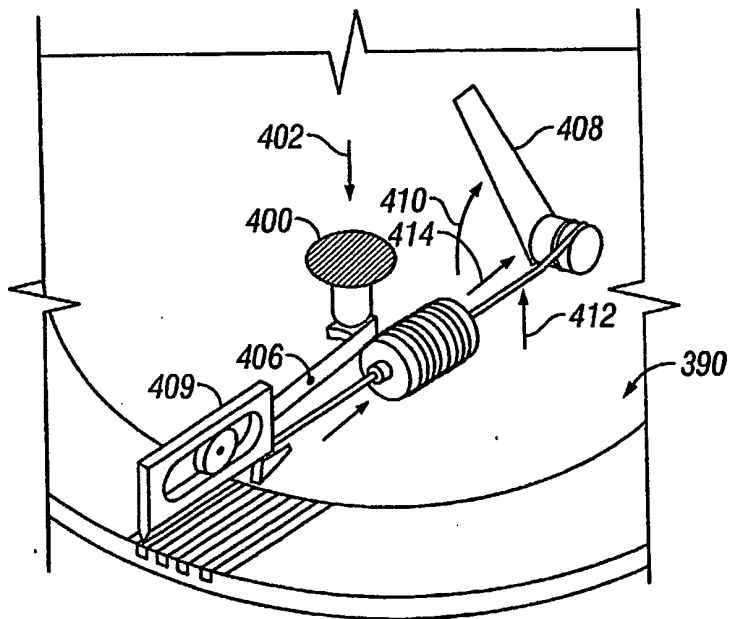

FIG. 38

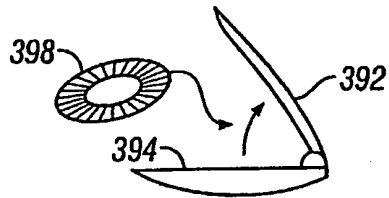

FIG. 39

16/63

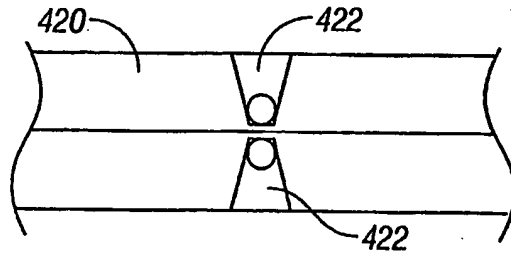

FIG. 40

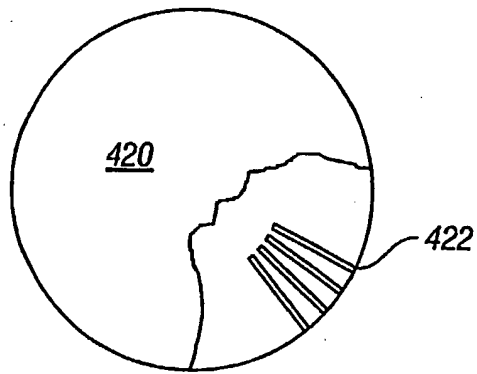

FIG. 41

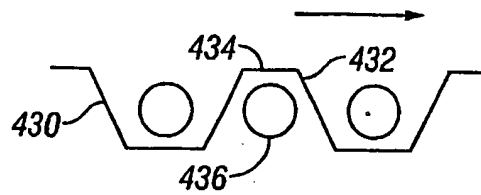

FIG. 42

17/63

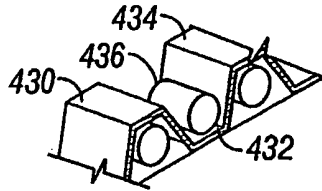

FIG. 43

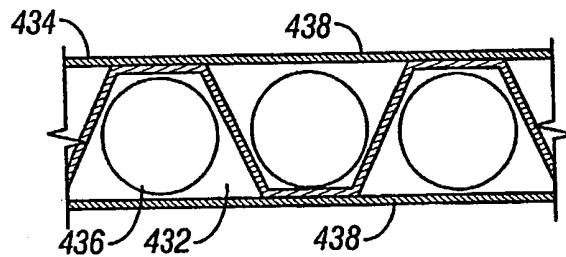

FIG. 44

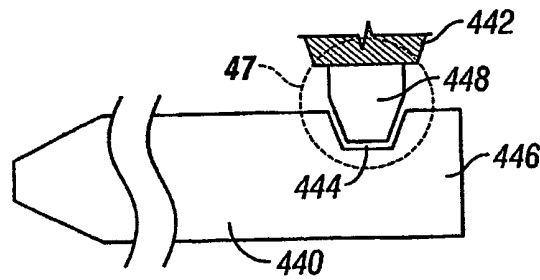

FIG. 45

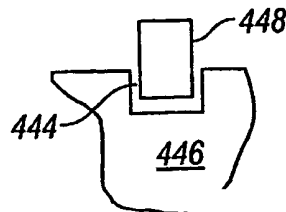

FIG. 46

18/63

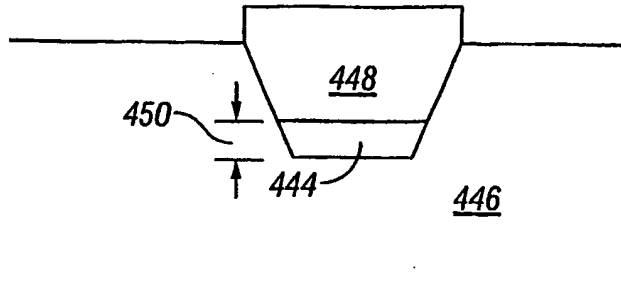

FIG. 47

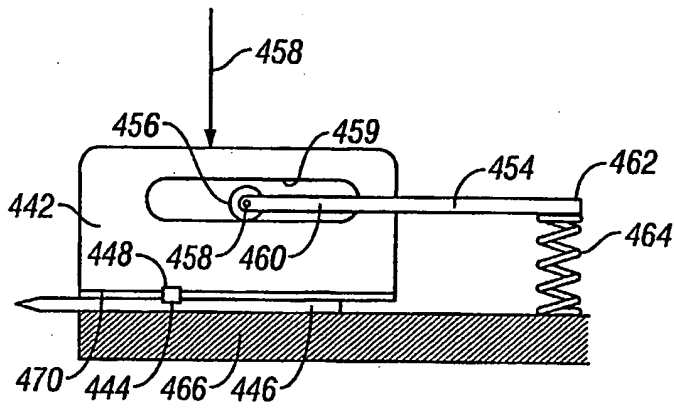

FIG. 48

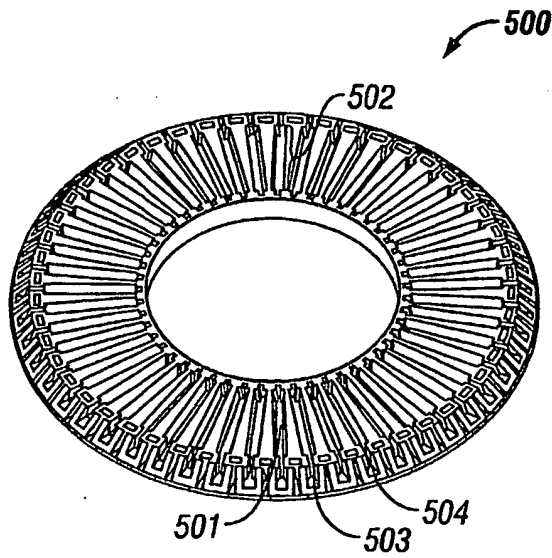

FIG. 49

19/63

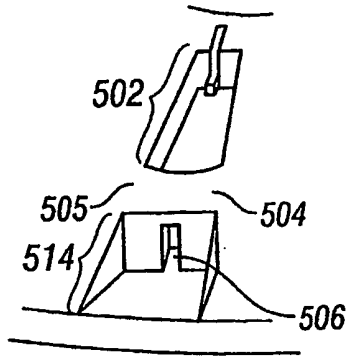

FIG. 50

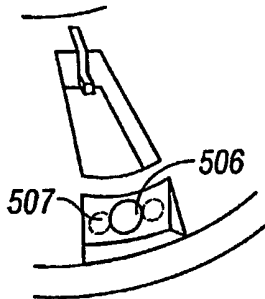

FIG. 51

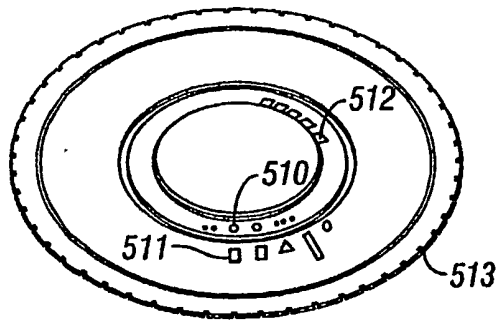

FIG. 52

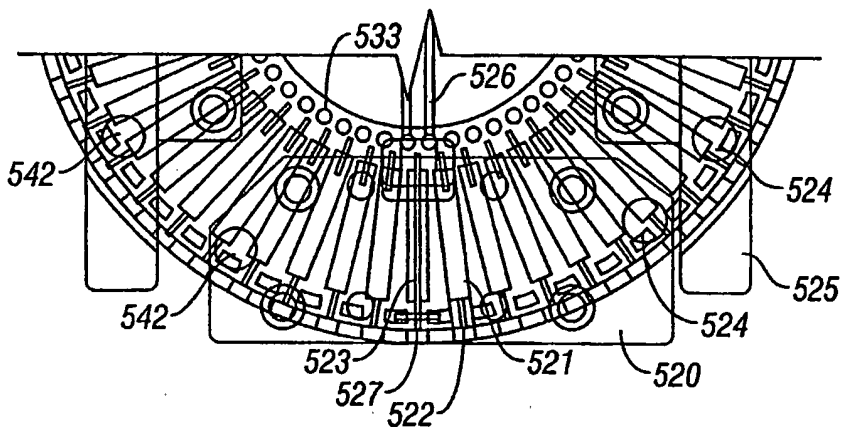

FIG. 53A

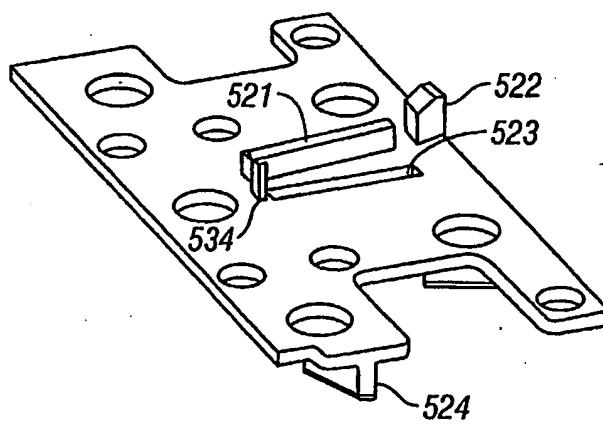

FIG. 53B

21/63

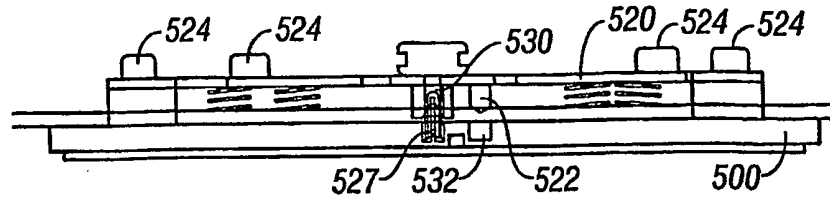

FIG. 54A

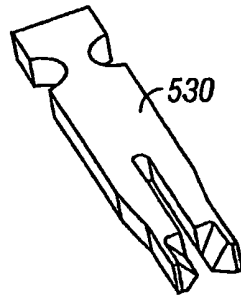

FIG. 54B

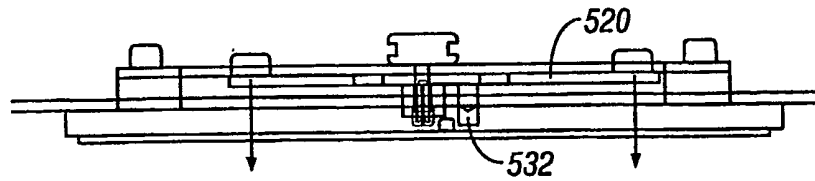

FIG. 54C

22/63

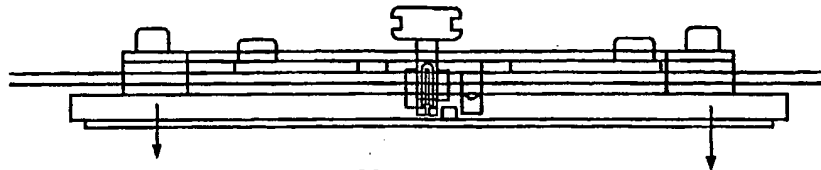

FIG. 54D

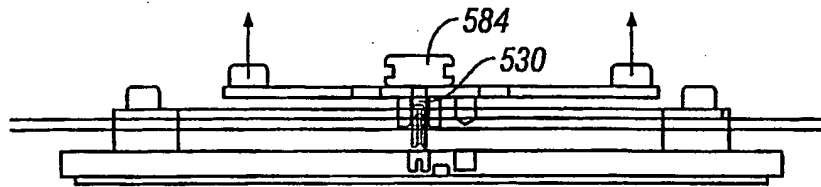

FIG. 54E

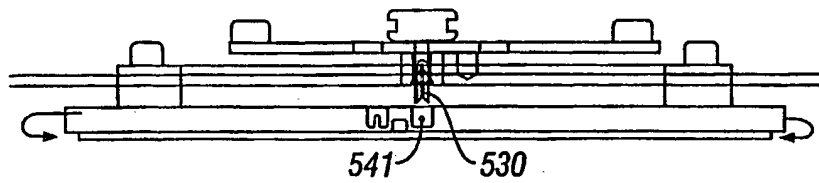

FIG. 54F

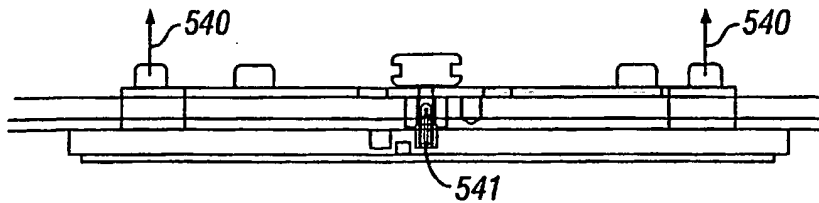

FIG. 54G

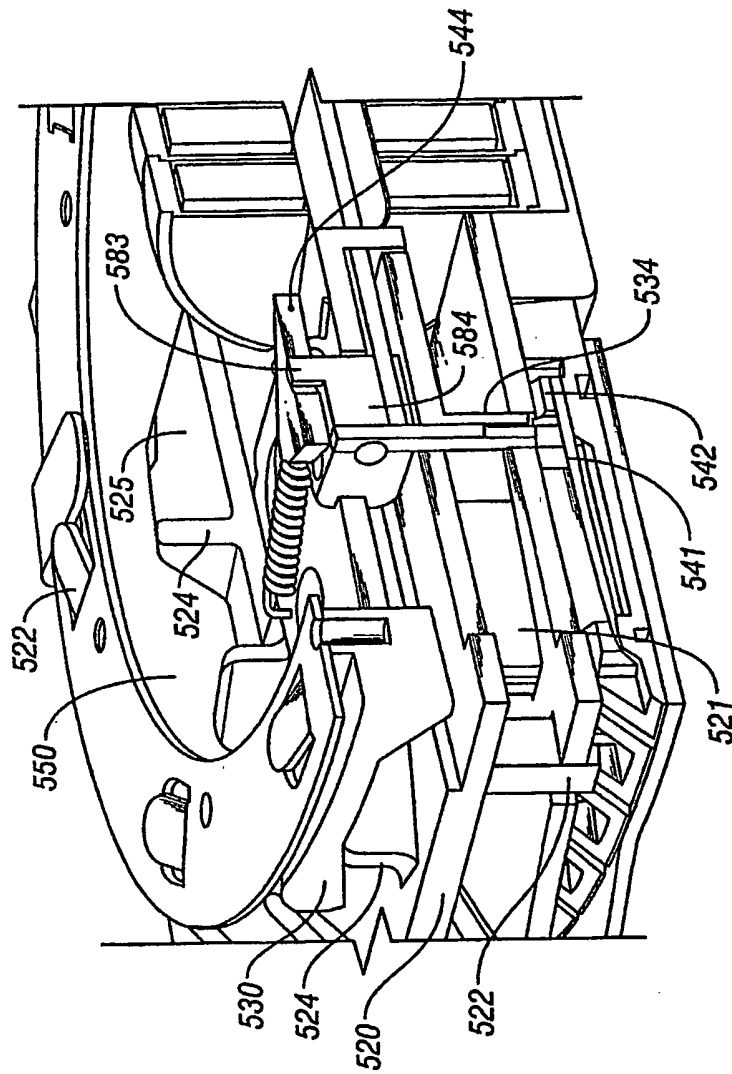

FIG. 55A

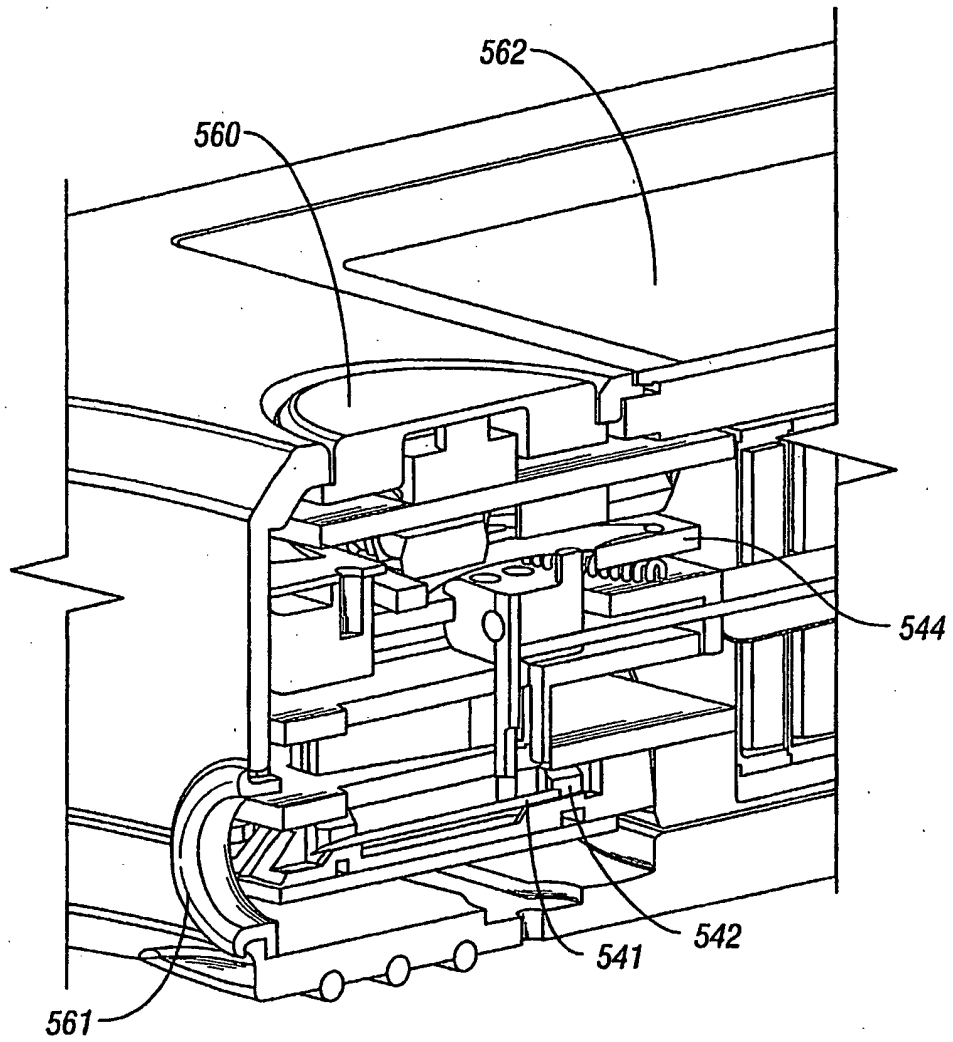

FIG. 55B

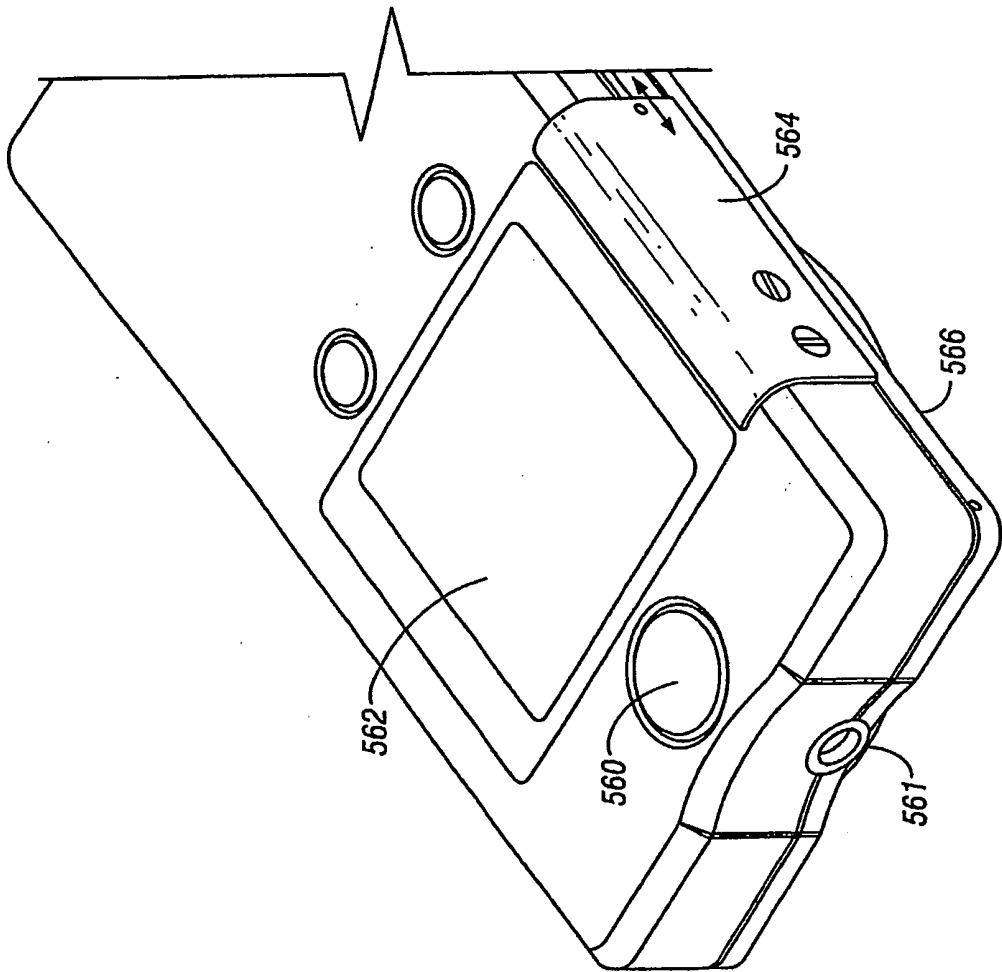

FIG. 56A

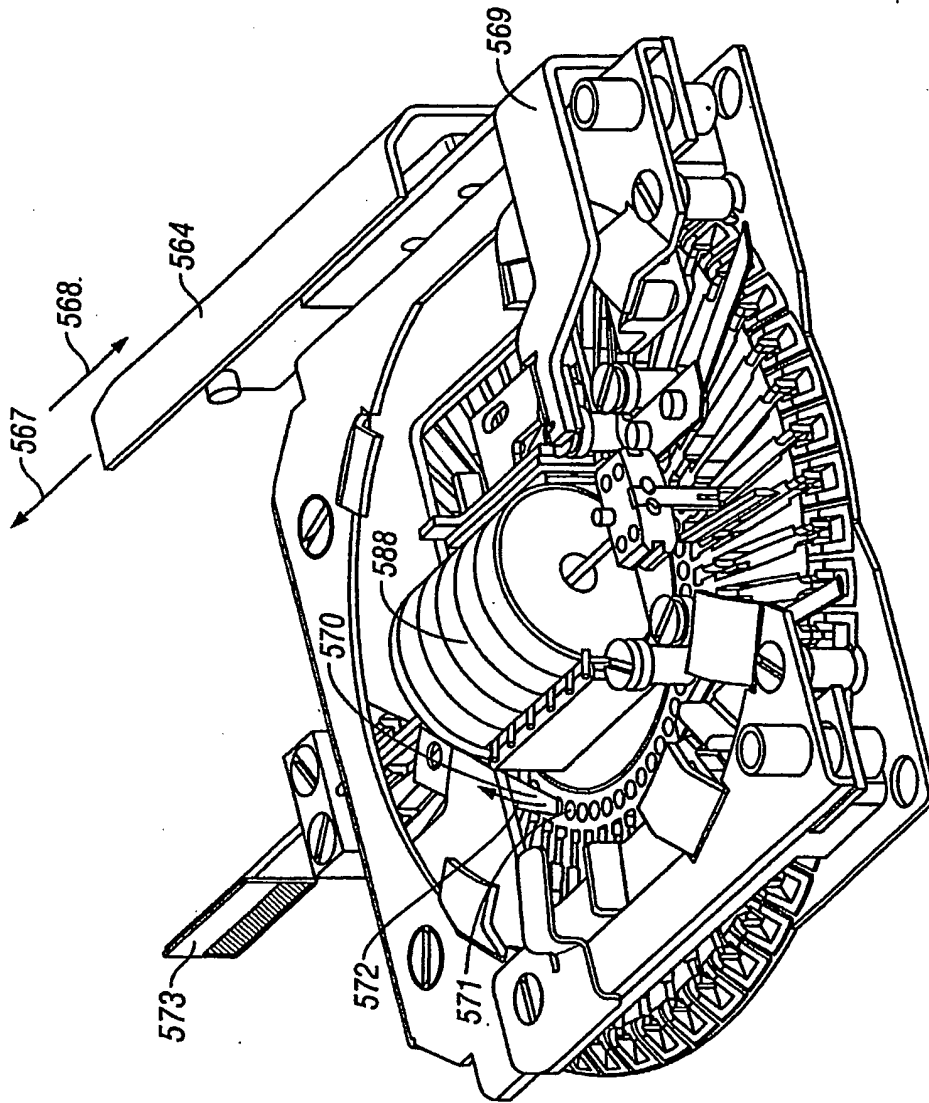

FIG. 56B

27/63

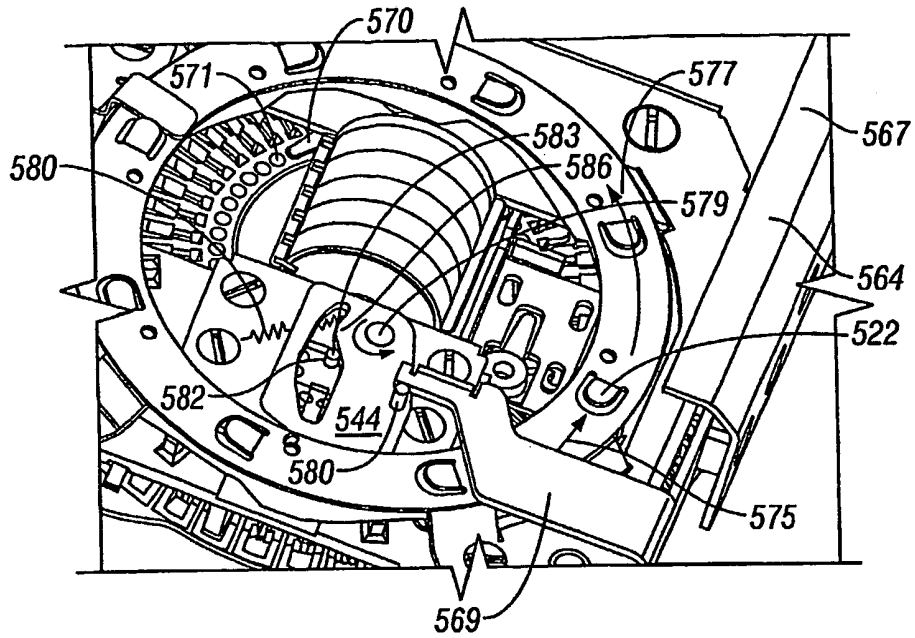

FIG. 56C

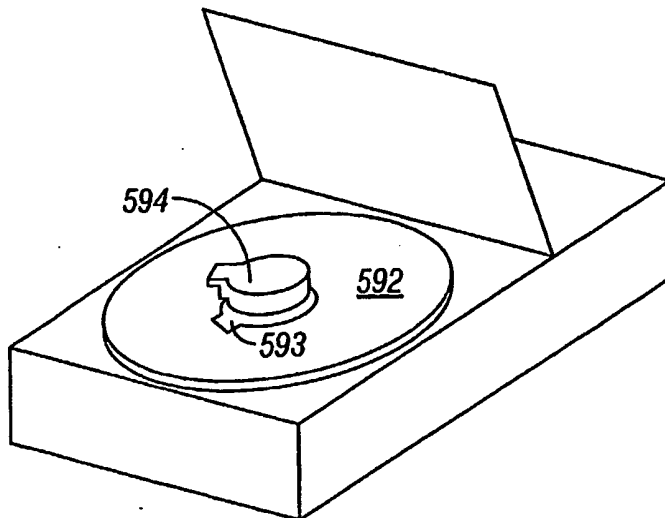

FIG. 56D

28/63

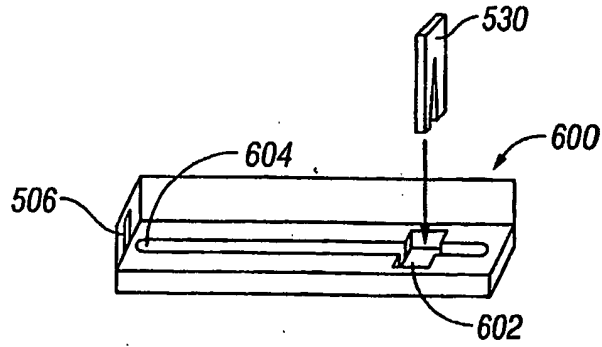

FIG. 57

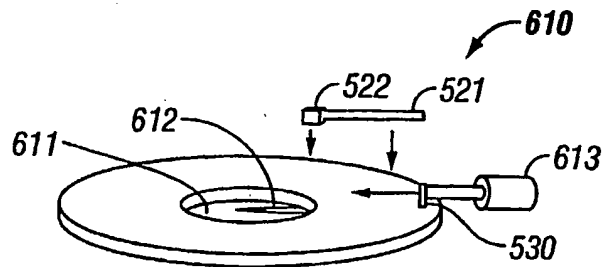

FIG. 58

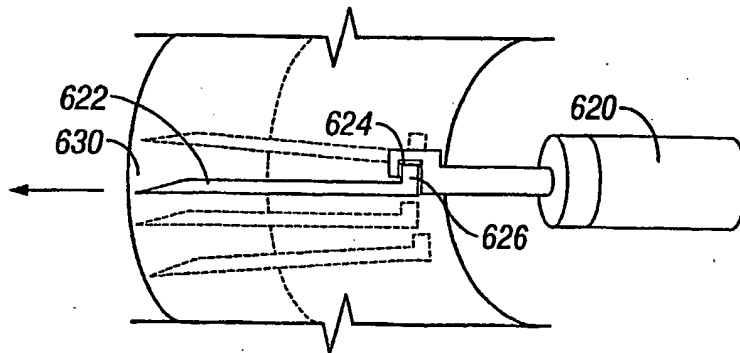

FIG. 59

29/63

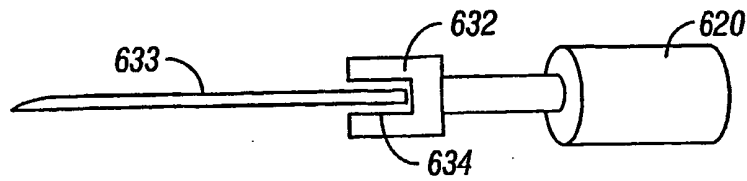

FIG. 60A

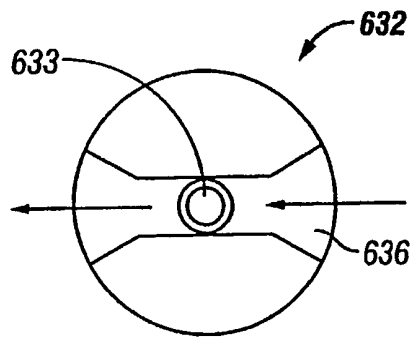

FIG. 60B

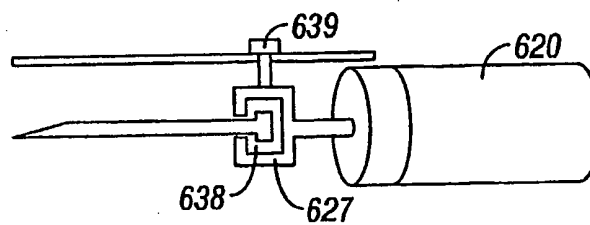

FIG. 60C

30/63

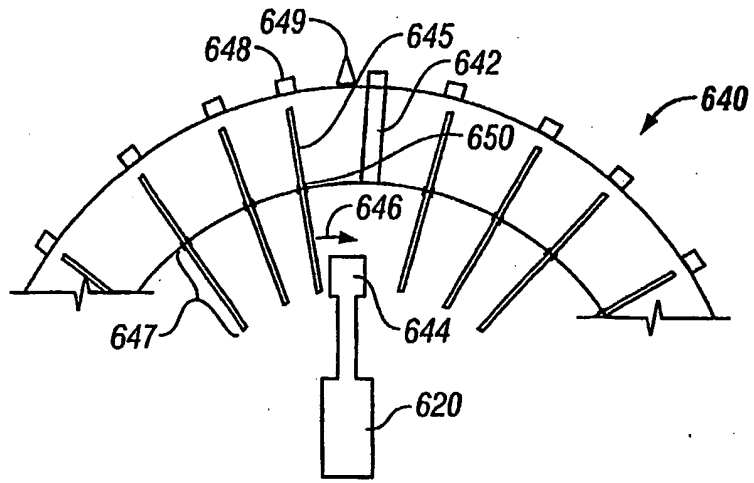

FIG. 61

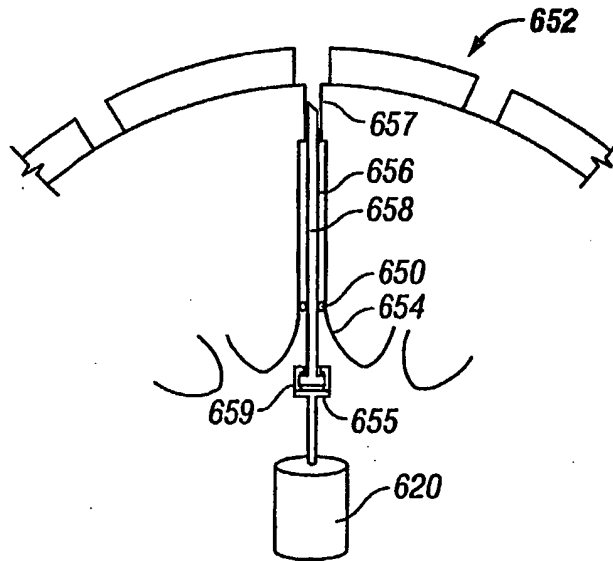

FIG. 62

31/63

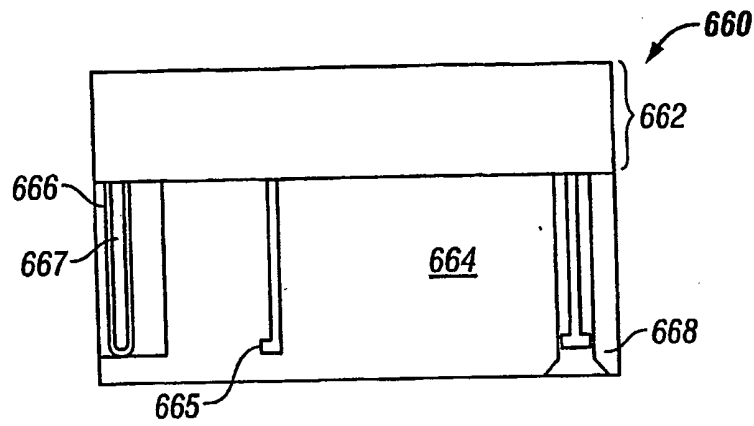

FIG. 63

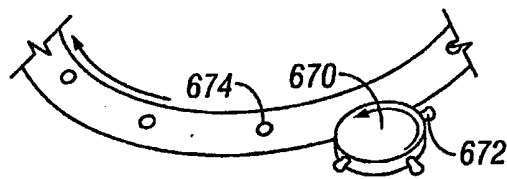

FIG. 64A

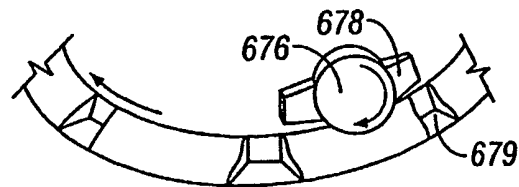

FIG. 64B

32/63

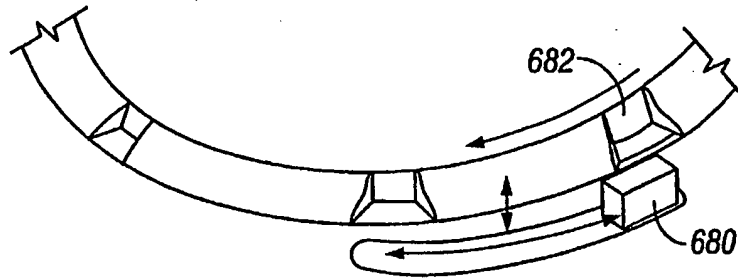

FIG. 64C

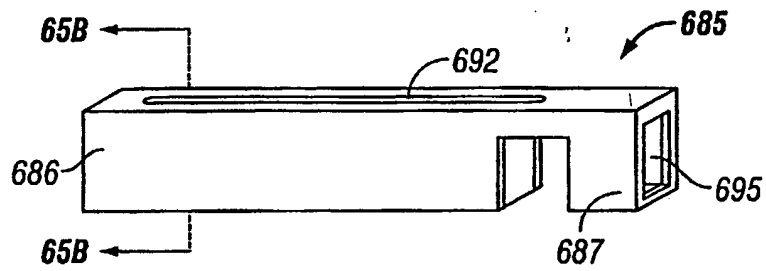

FIG. 65A

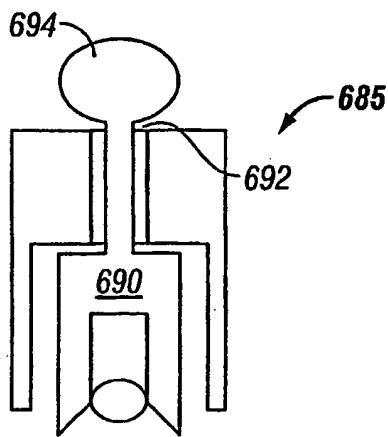

FIG. 65B

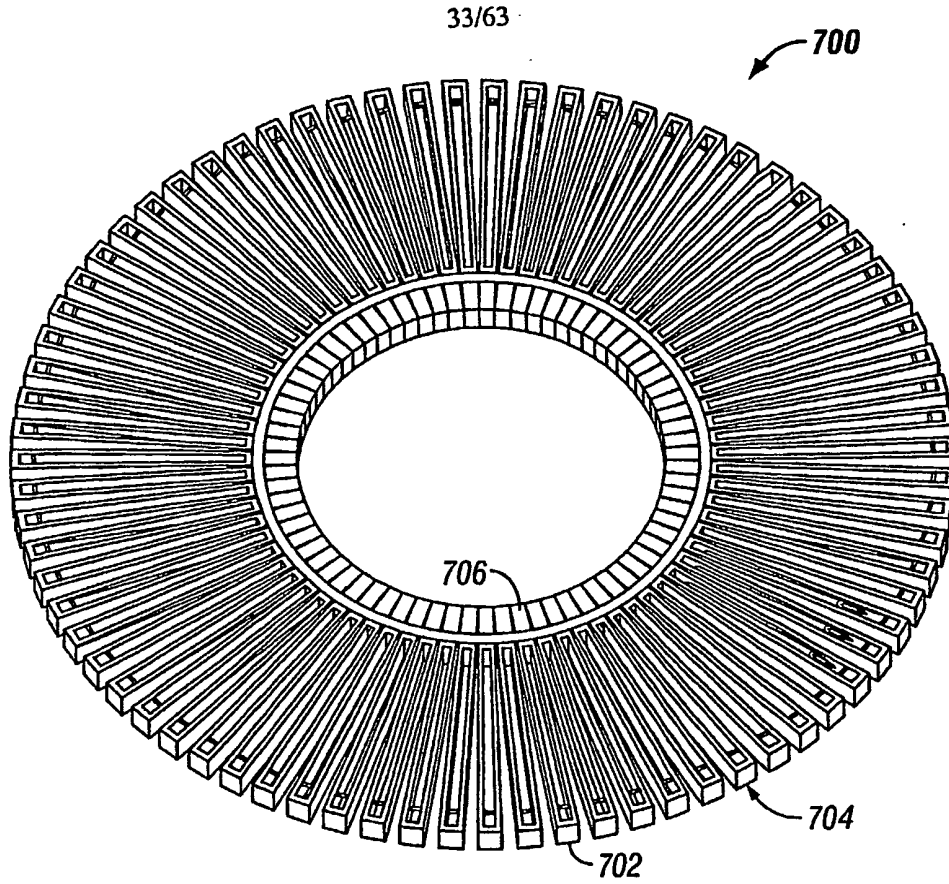

FIG. 66

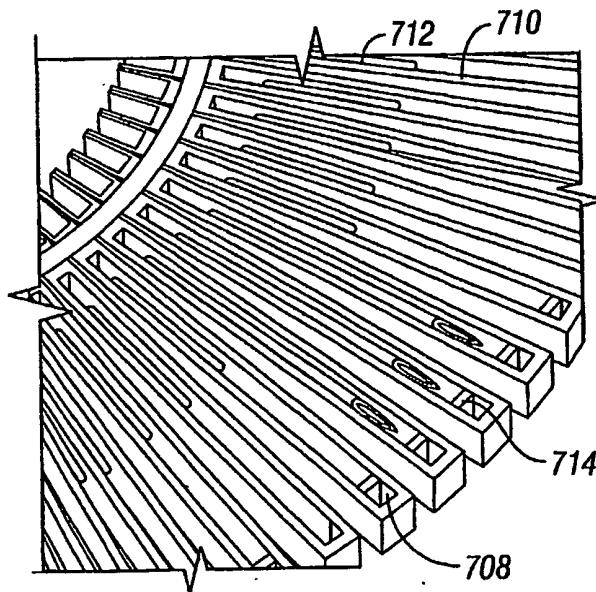

FIG. 67

SUBSTITUTE SHEET (RULE 26)

34/63

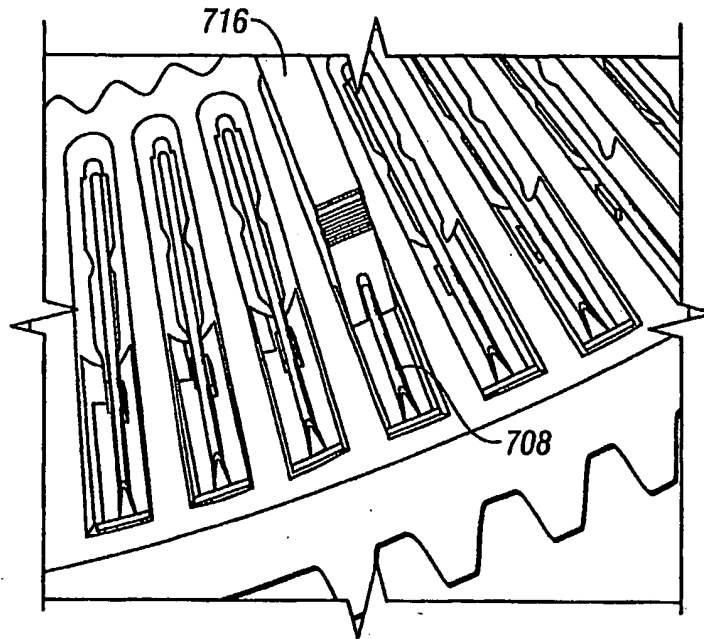

FIG. 68

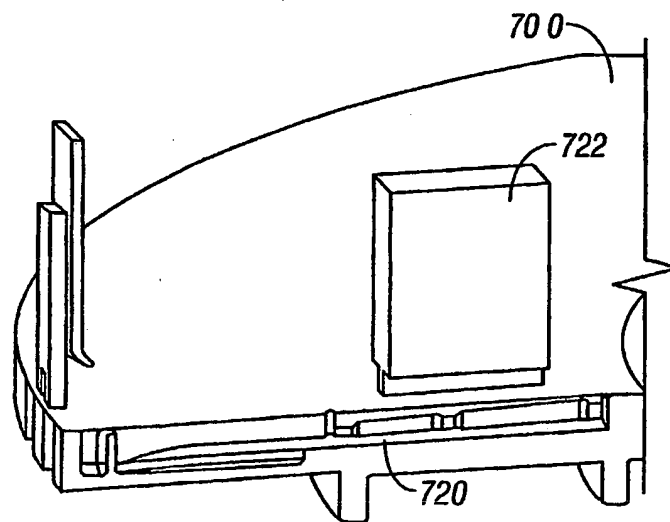

FIG. 69A

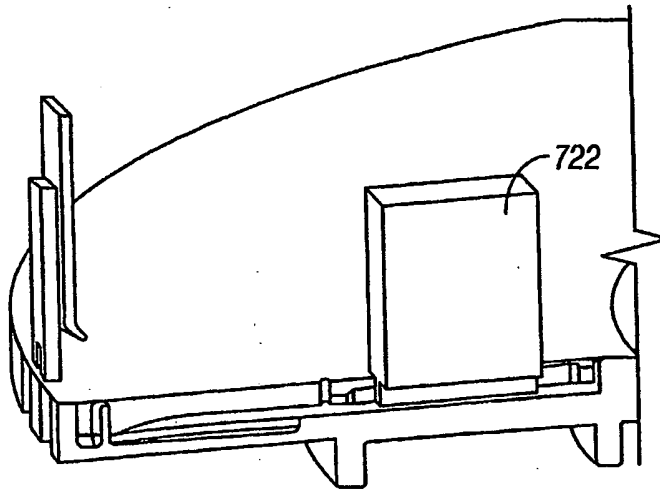

FIG. 69B

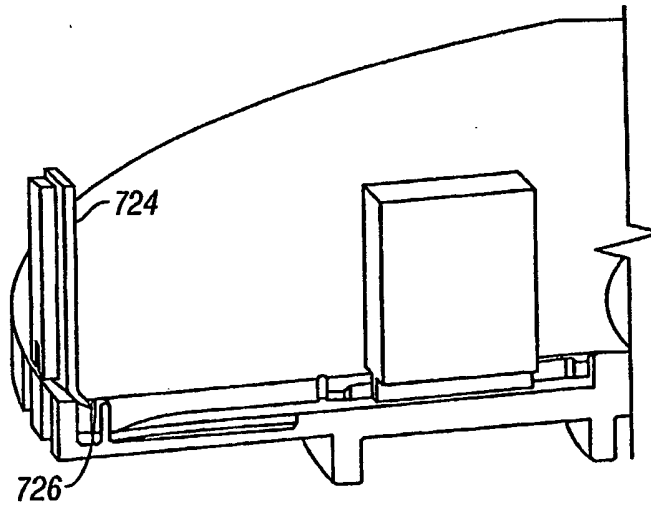

FIG. 69C

36/63

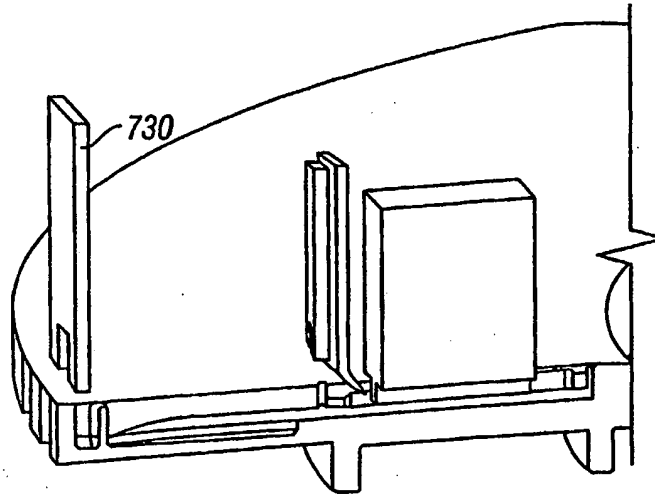

FIG. 69D

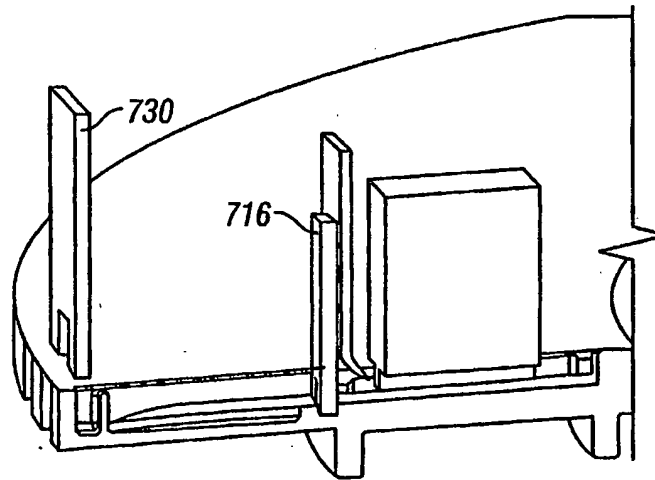

FIG. 69E

37/63

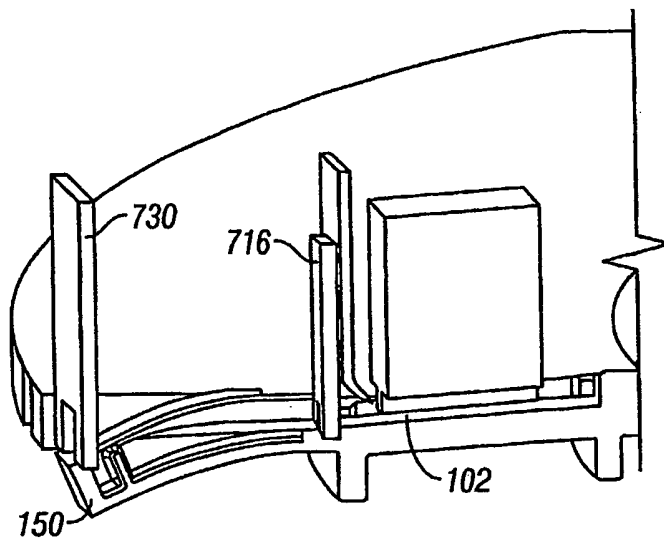

FIG. 69F

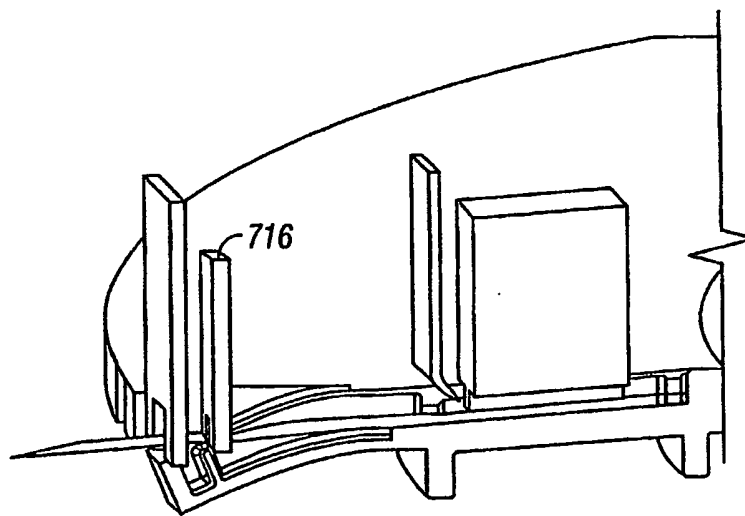

FIG. 69G

38/63

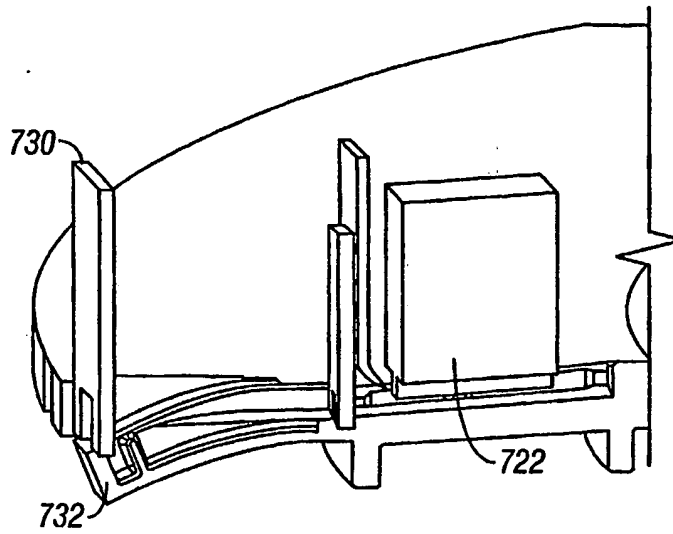

FIG. 69H

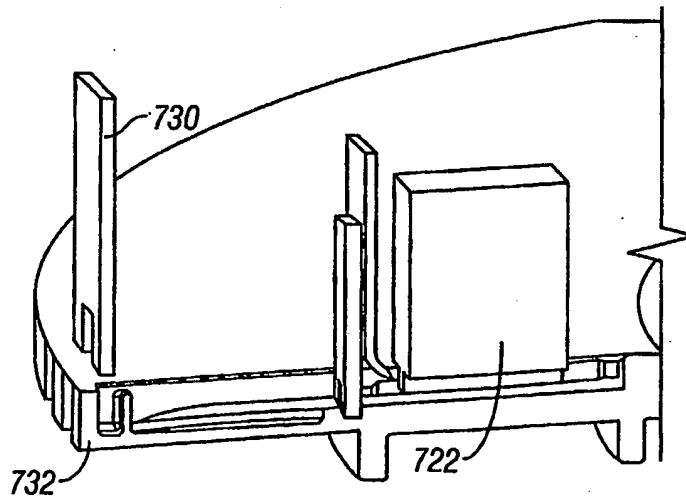

FIG. 69I

39/63

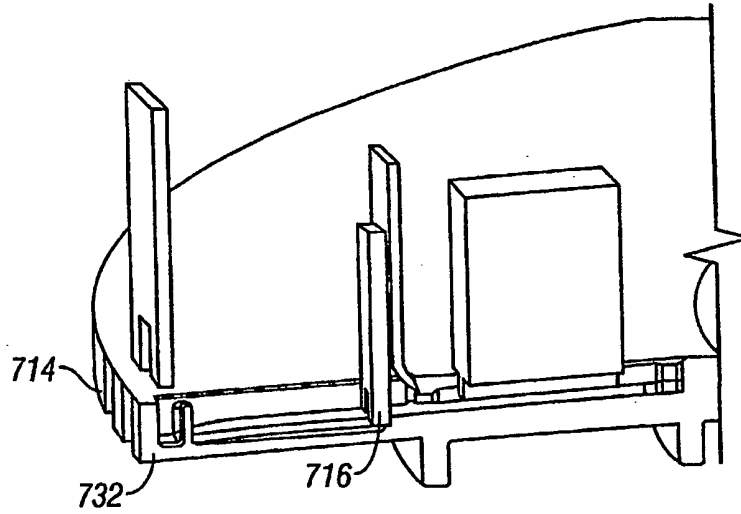

FIG. 69J

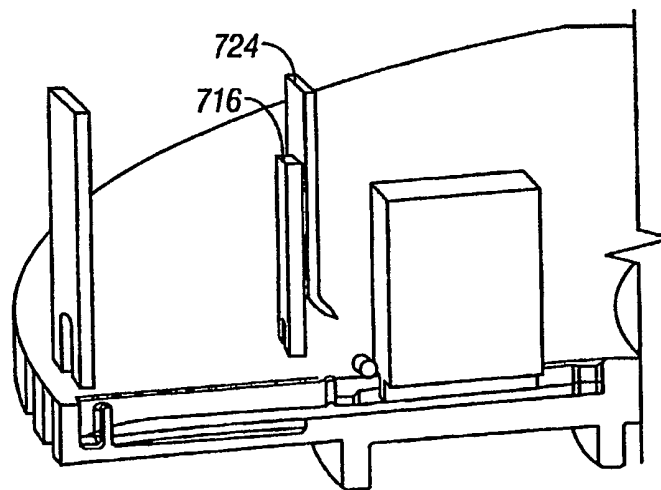

FIG. 69K

40/63

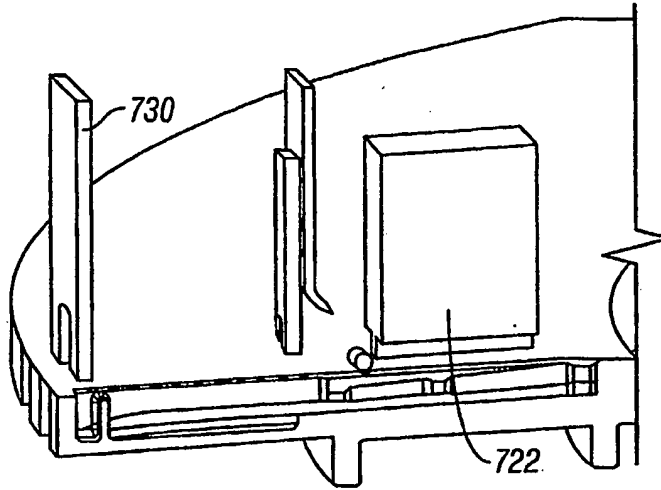

FIG. 69L

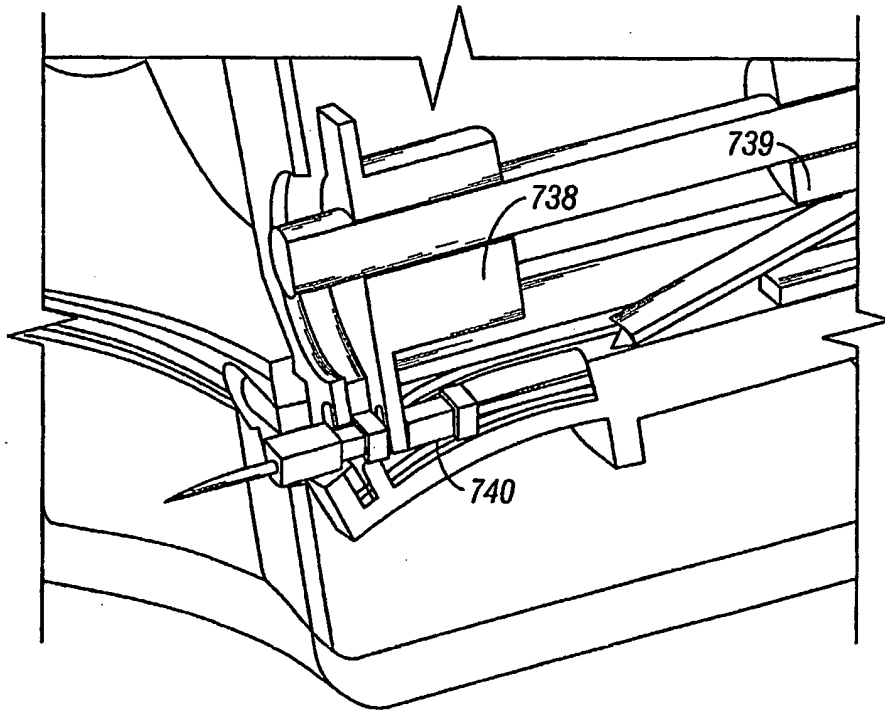

FIG. 70

41/63

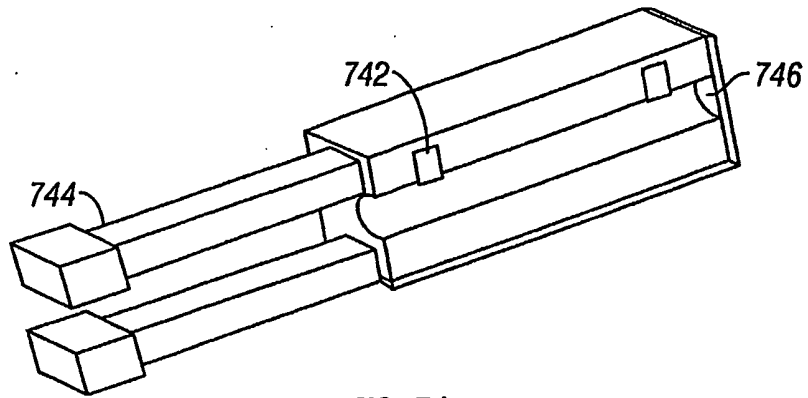

FIG. 71

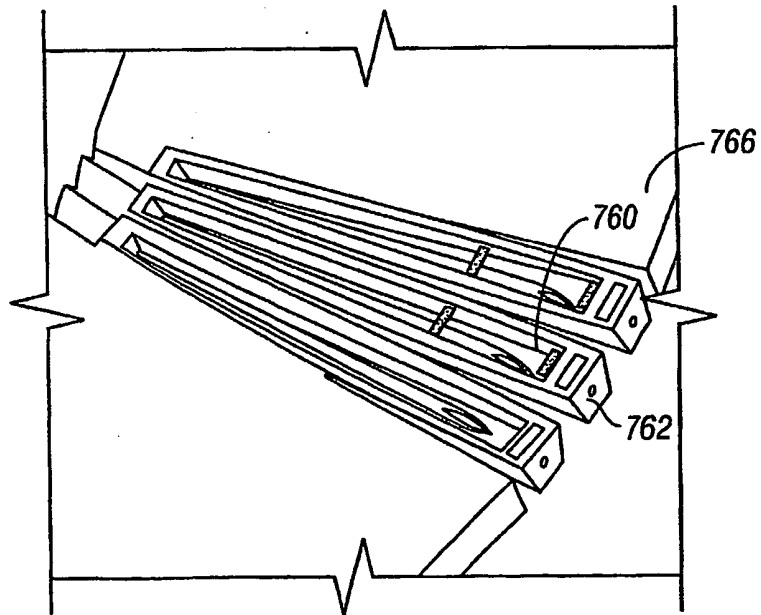

FIG. 72

42/63

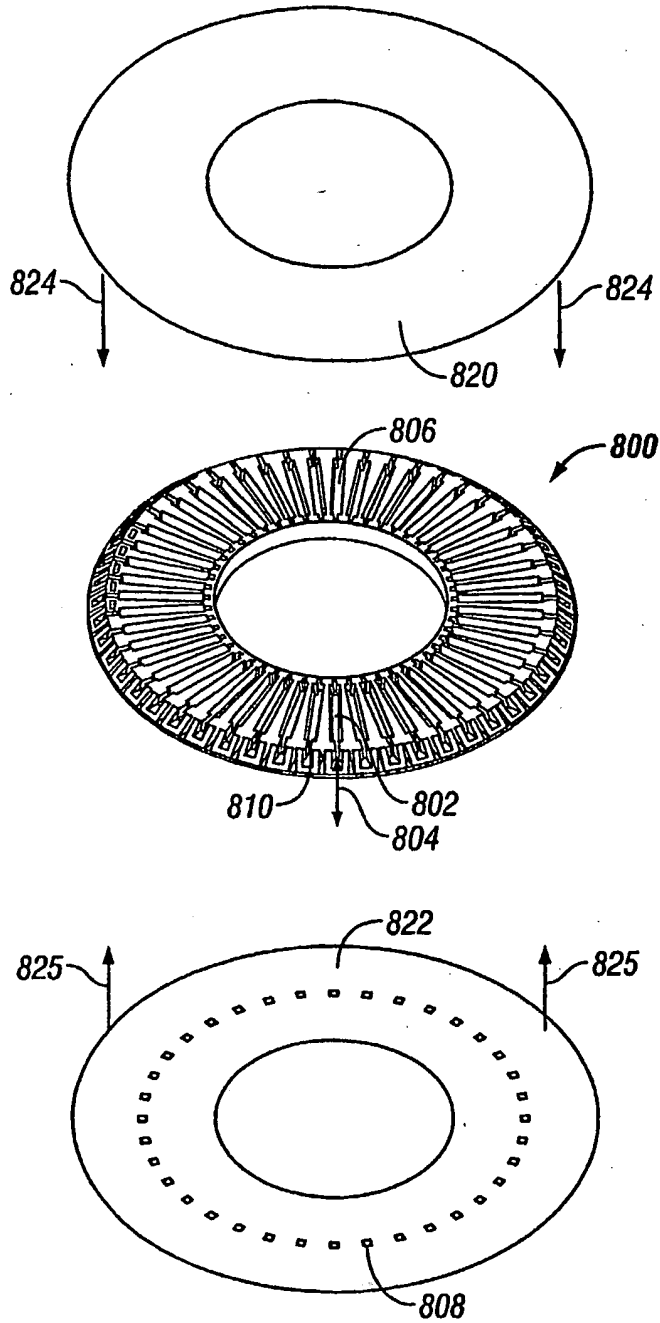

FIG. 73

43/63

800

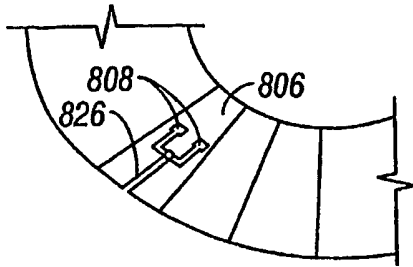

FIG. 74

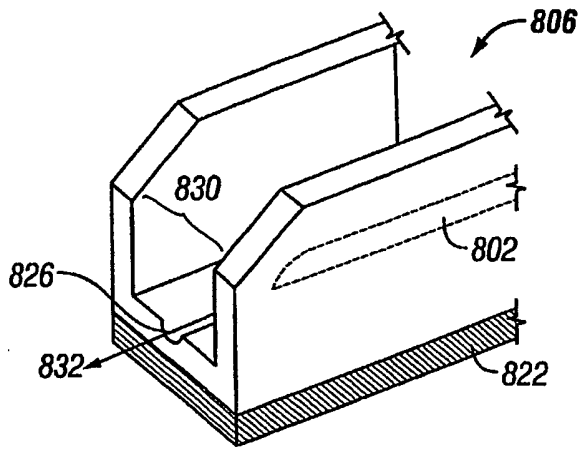

FIG. 75

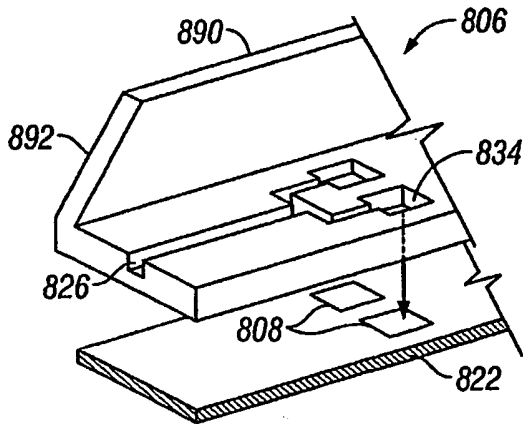

FIG. 76

44/63

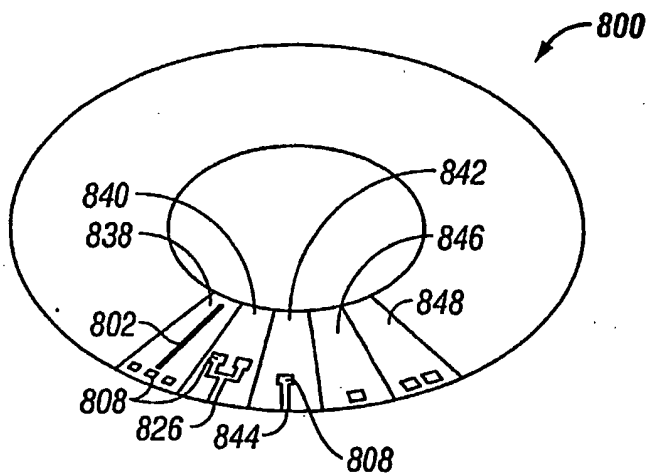

FIG. 77

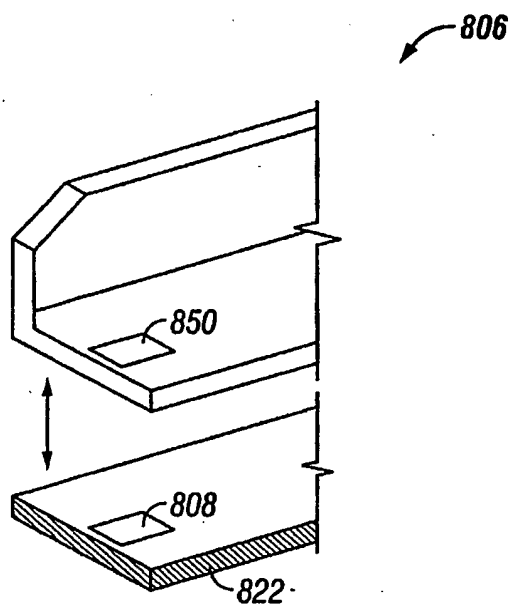

FIG. 78

45/63

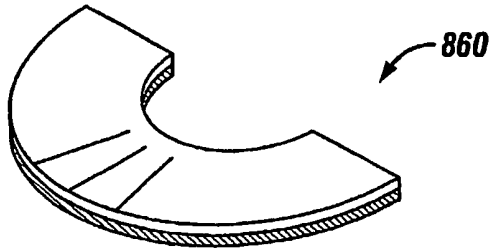

FIG. 79

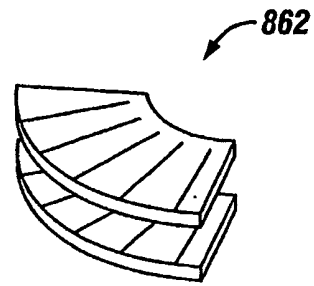

FIG. 80

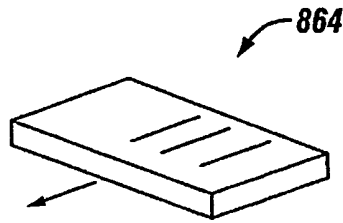

FIG. 81

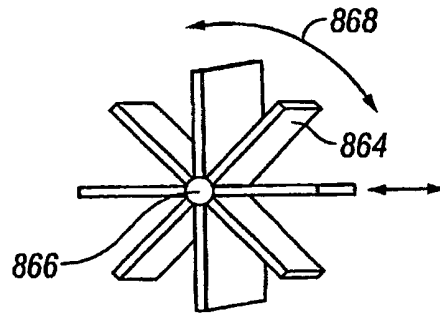

FIG. 82

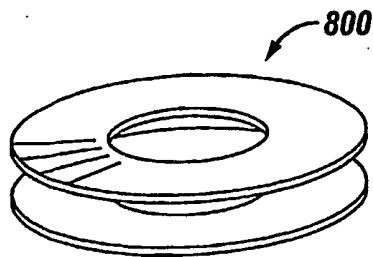

FIG. 83

46/63

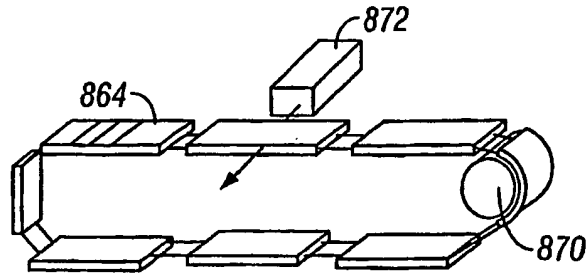

FIG. 84

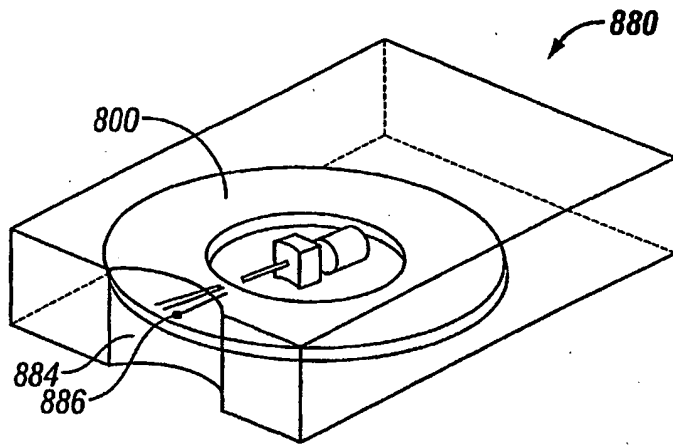

FIG. 85

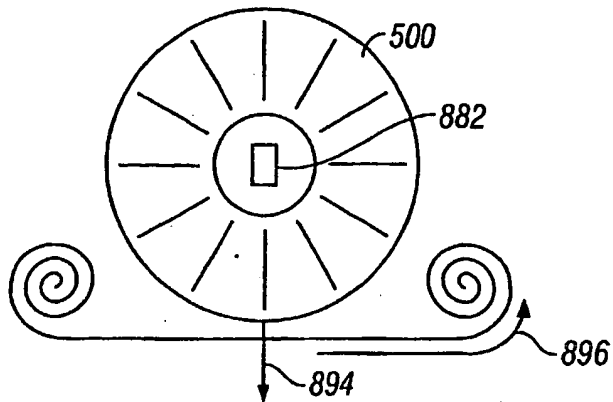

FIG. 86

47/63

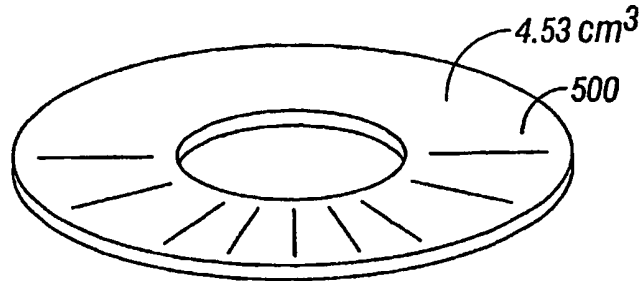

FIG. 87A

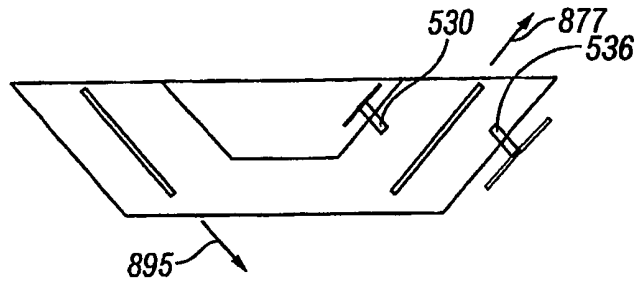

FIG. 87B

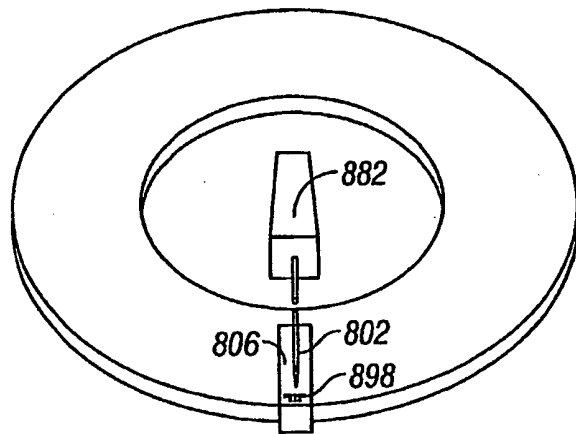
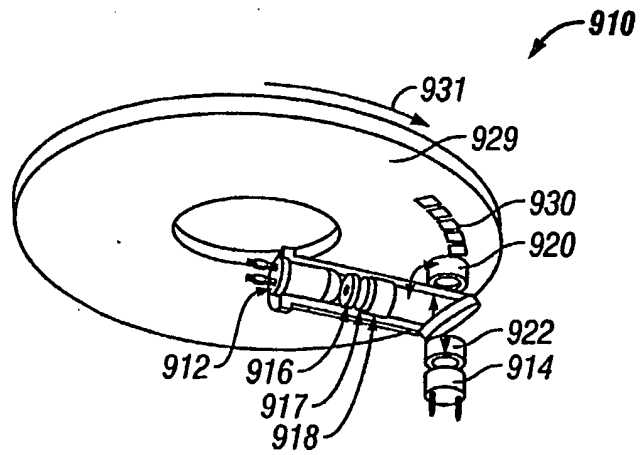
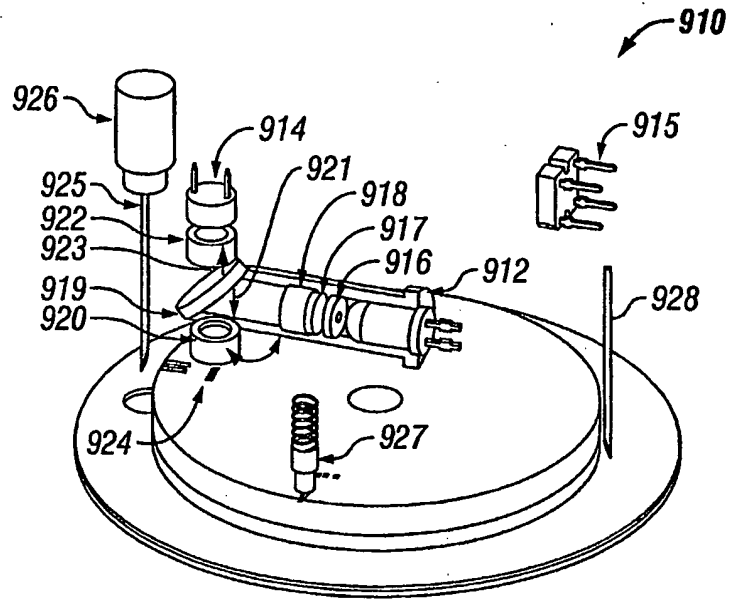

FIG. 88



49/63

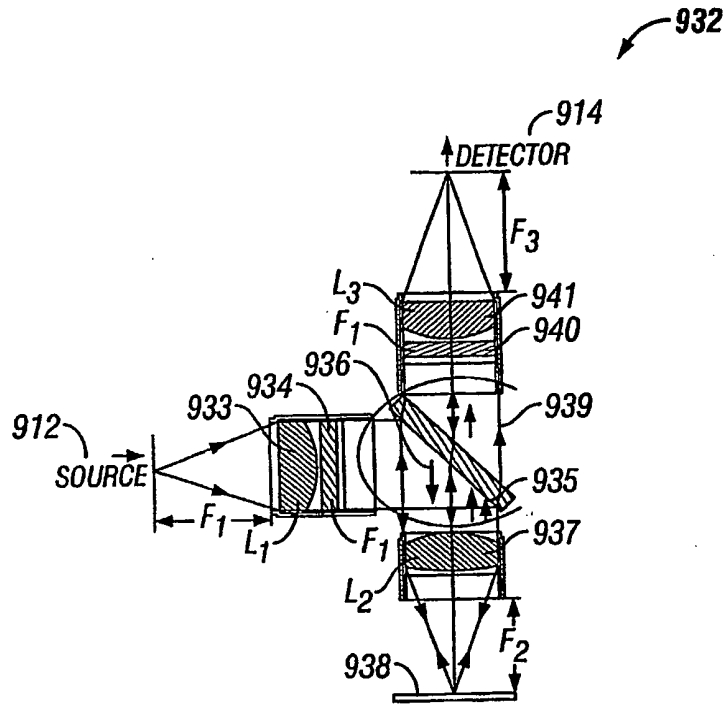

FIG. 91

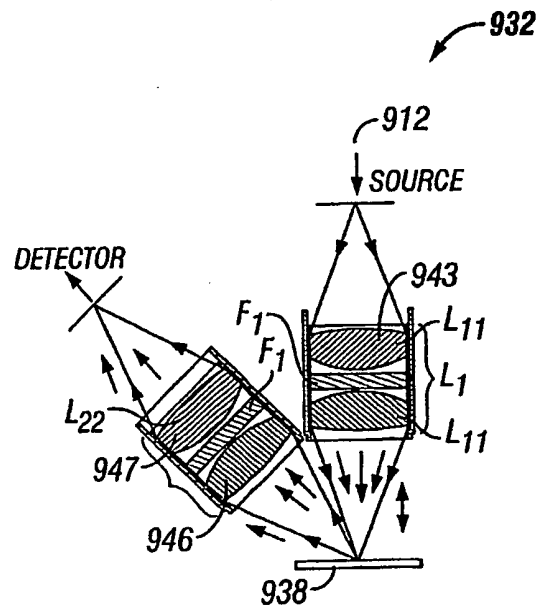

FIG. 92

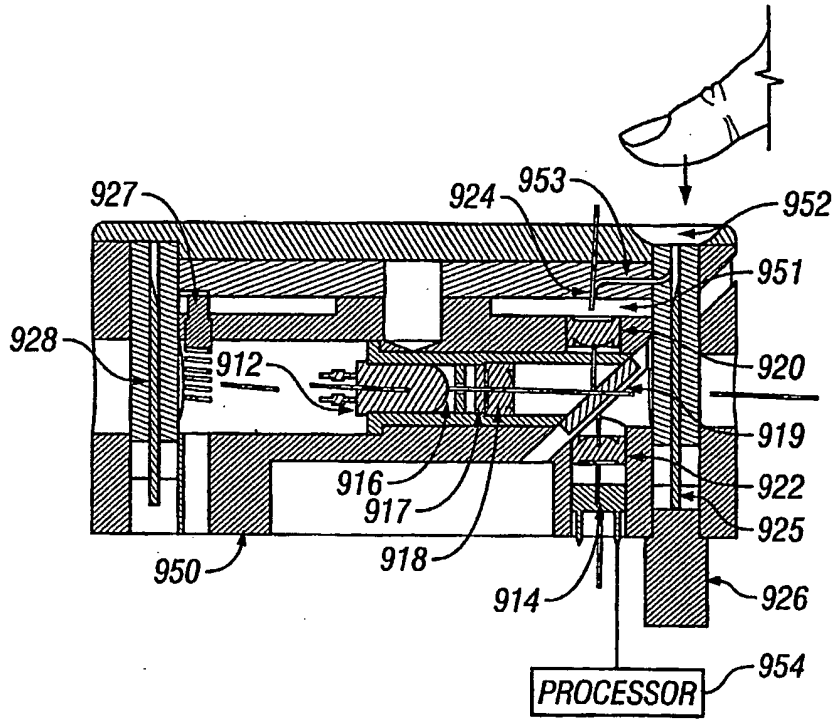

FIG. 93

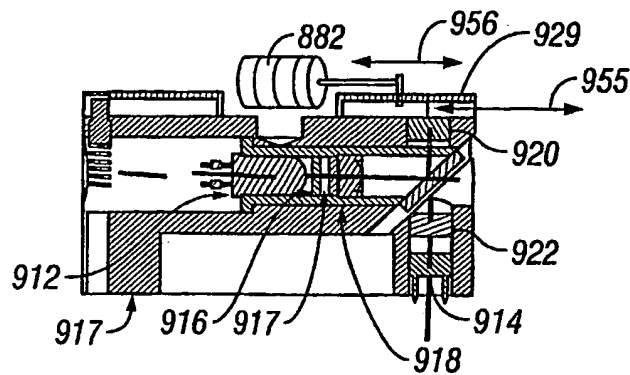

FIG. 94

51/63

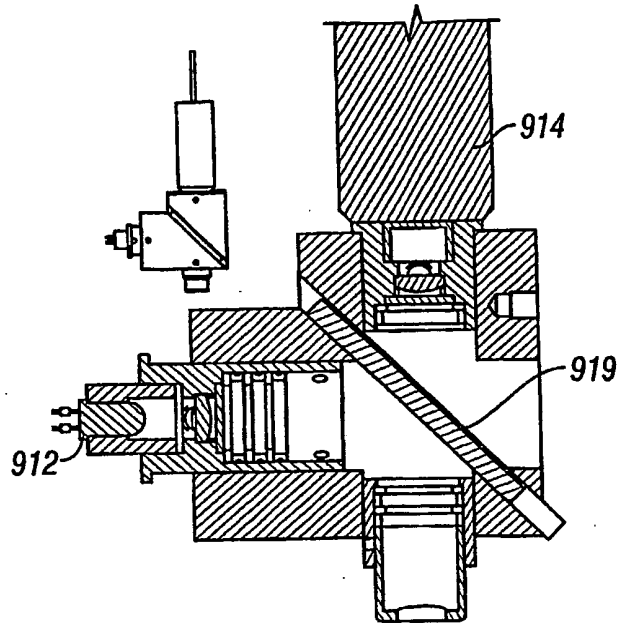

FIG. 95

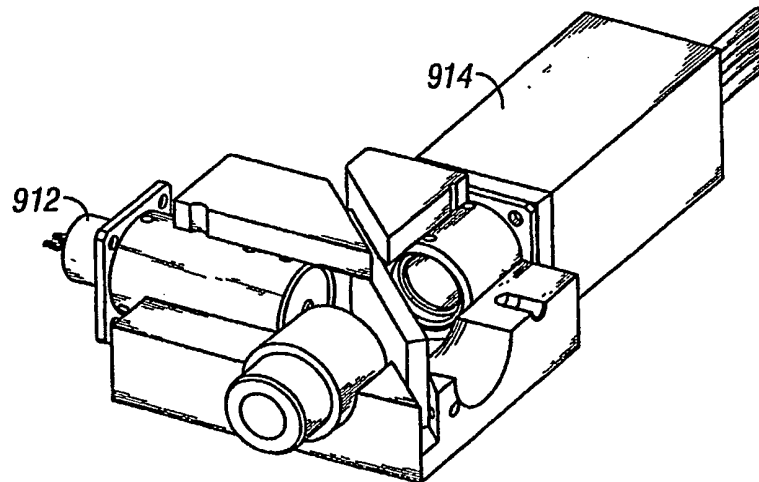

FIG. 96

52/63

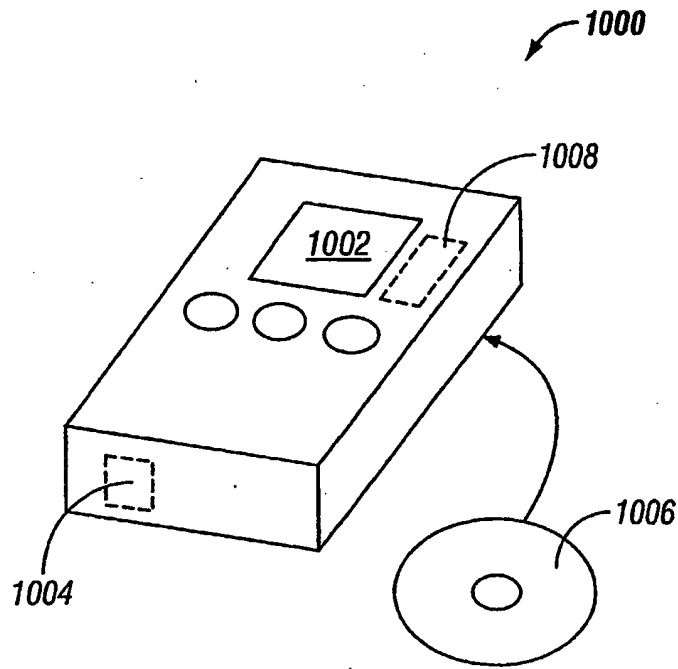

FIG. 97

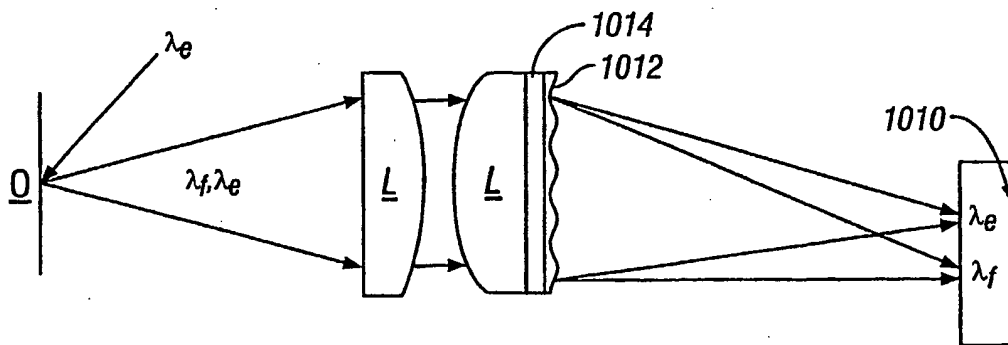

FIG. 98

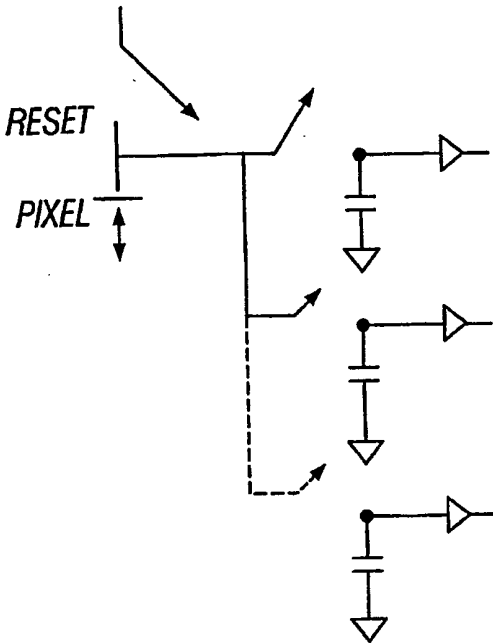

FIG. 99

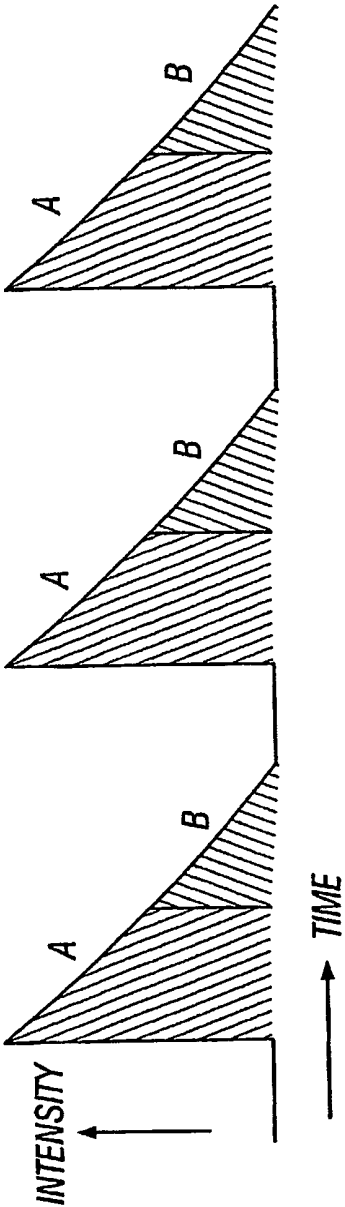

FIG. 100

54/63

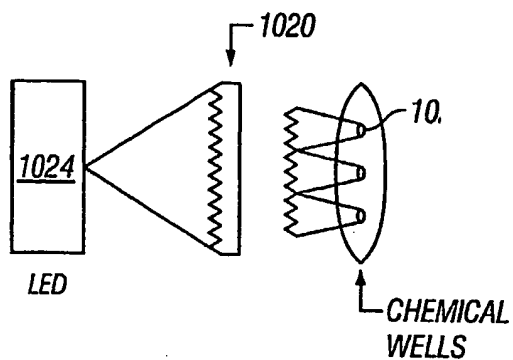

FIG. 101

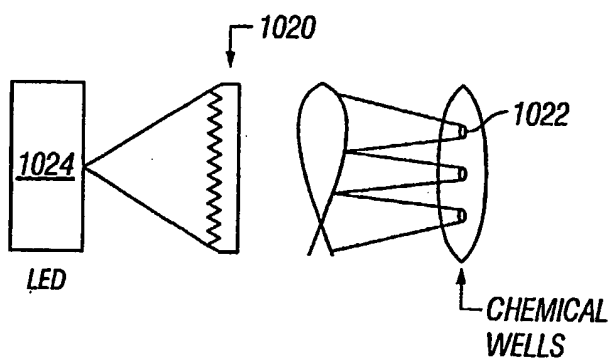

FIG. 102

55/63

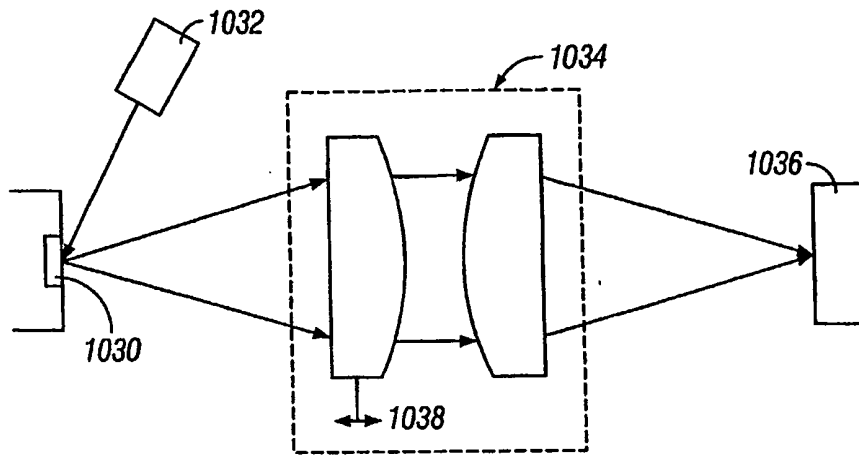

FIG. 103

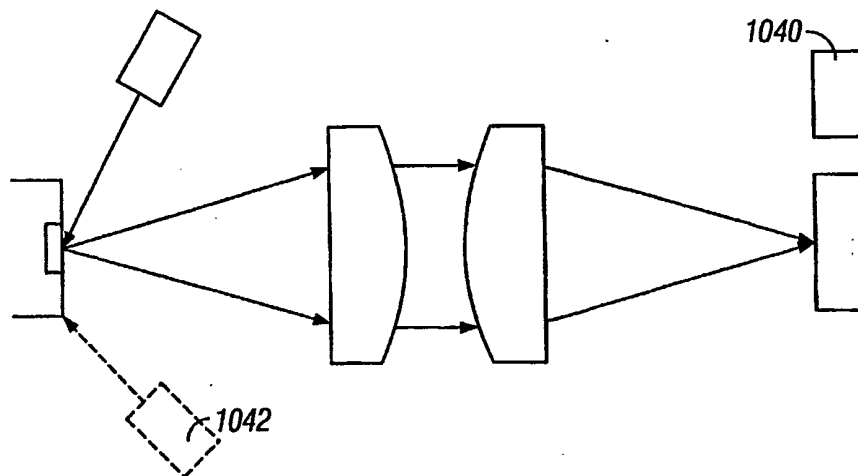

FIG. 104

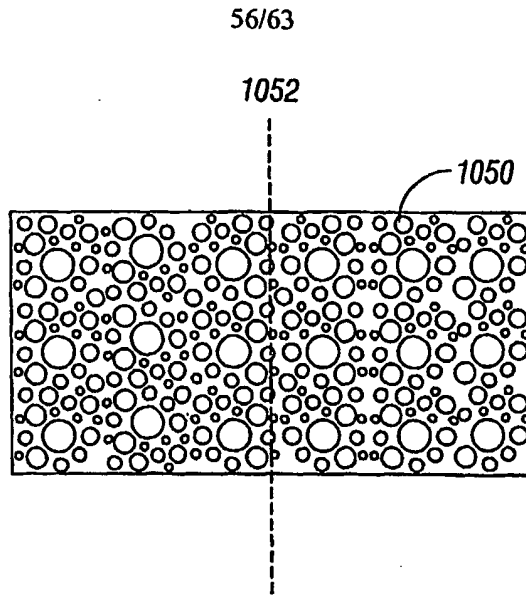

FIG. 105

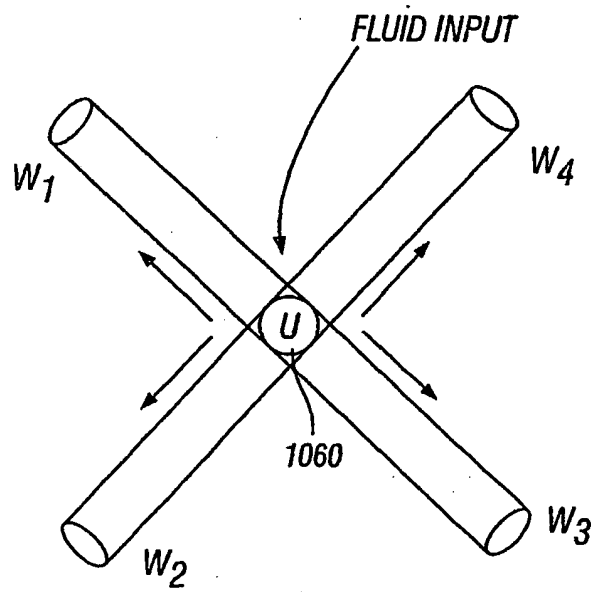

FIG. 106

57/63



FIG. 107A

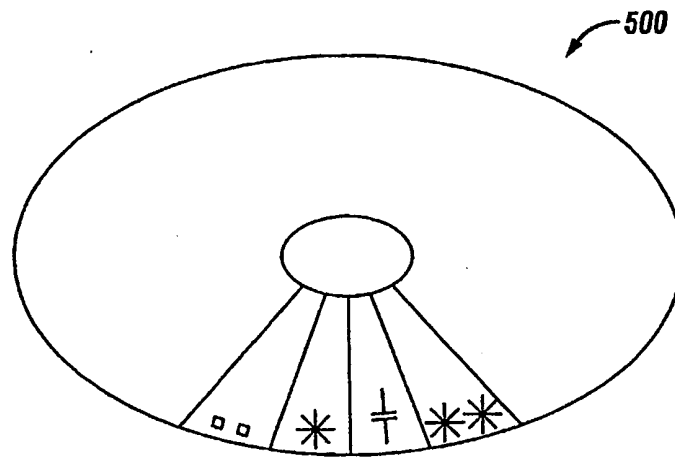

FIG. 107B

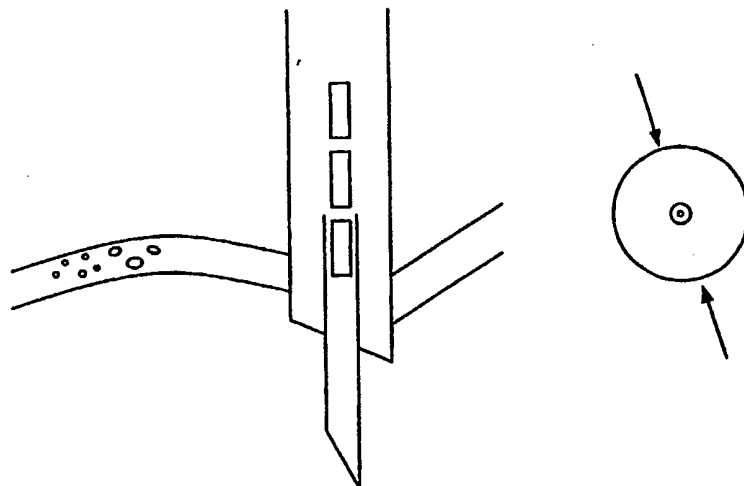

FIG. 108

58/63

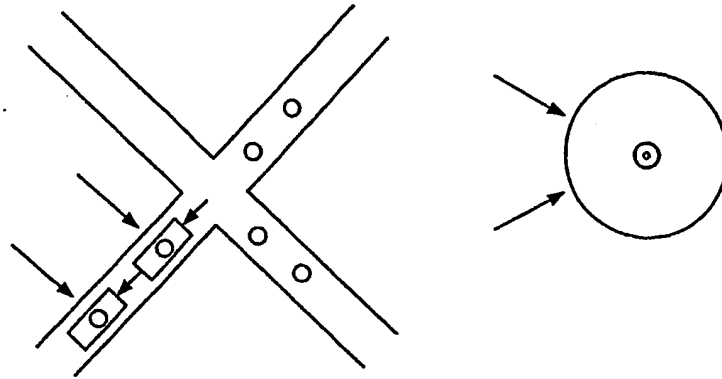

FIG. 109

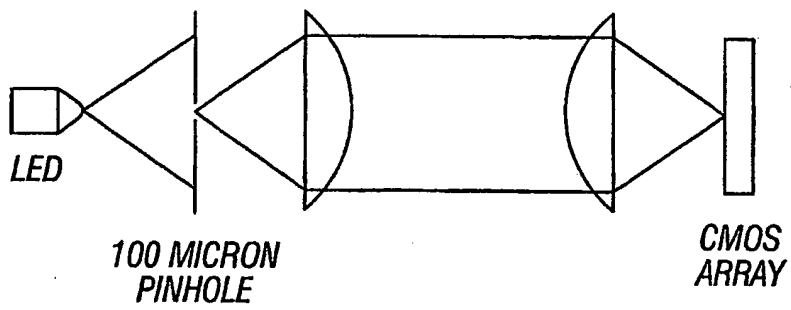
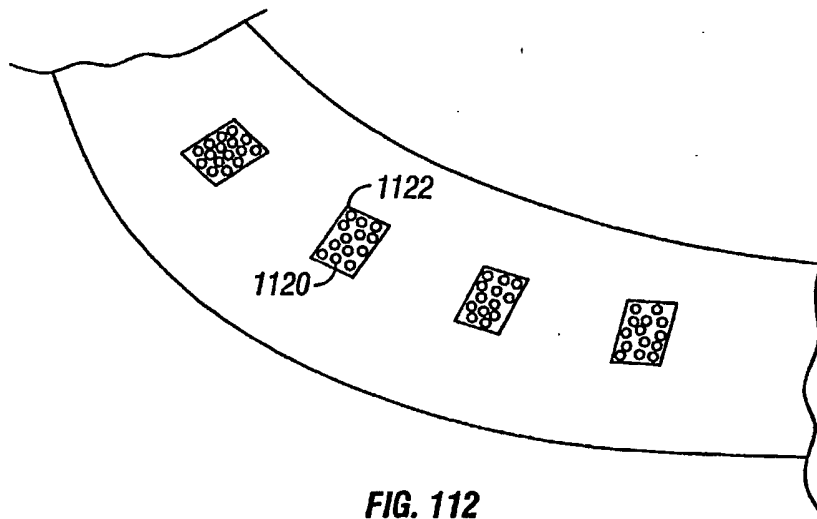
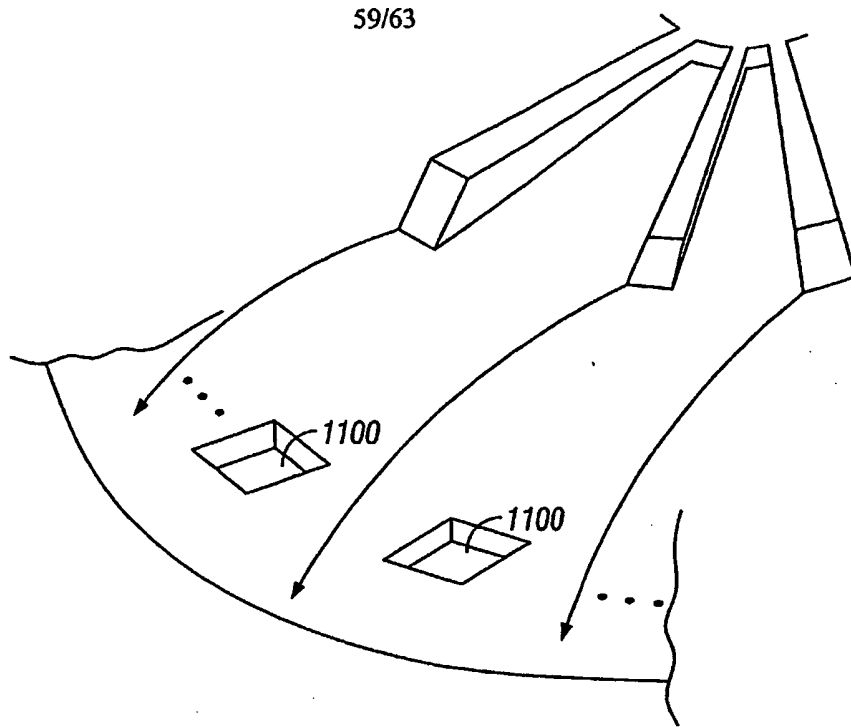

FIG. 110



60/63

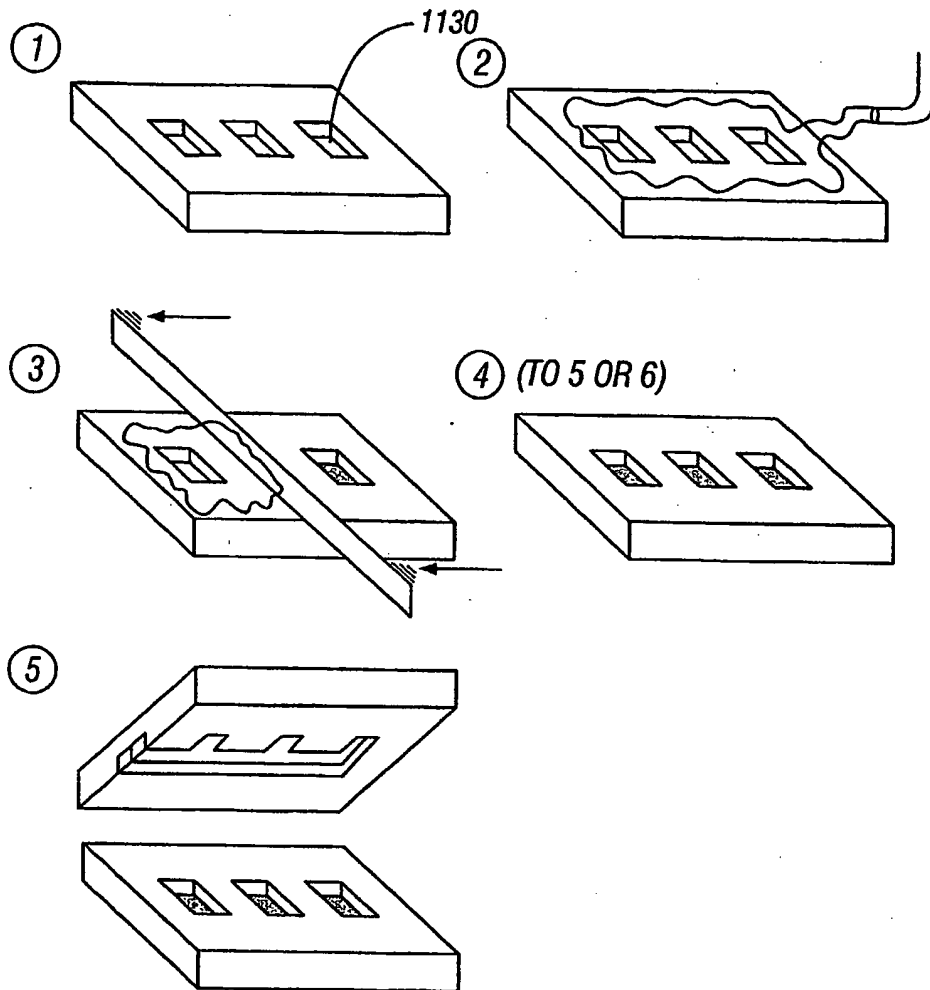

FIG. 113

61/63

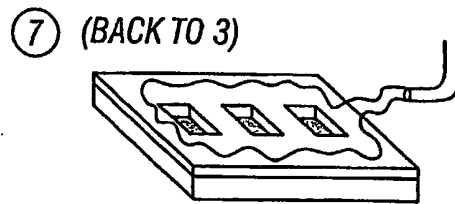
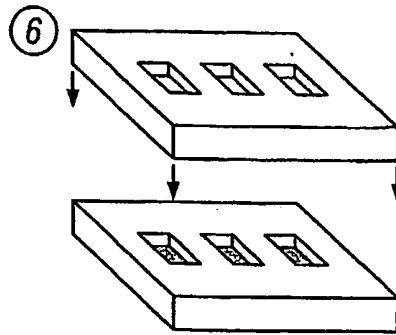

FIG. 114

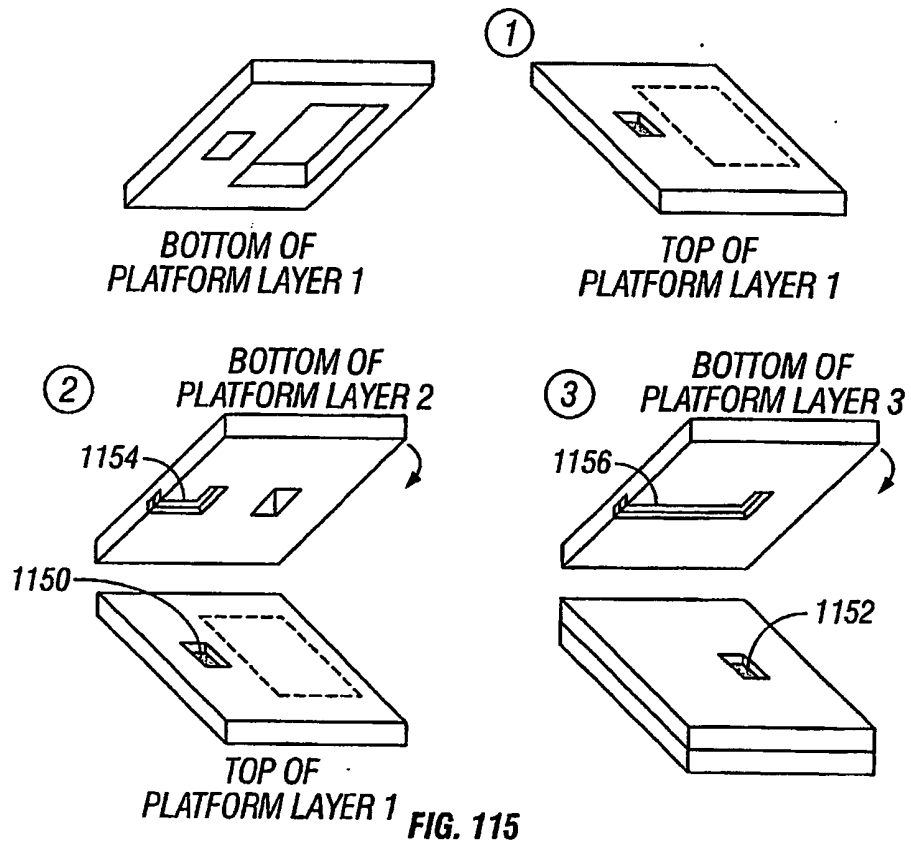

FIG. 115

62/63

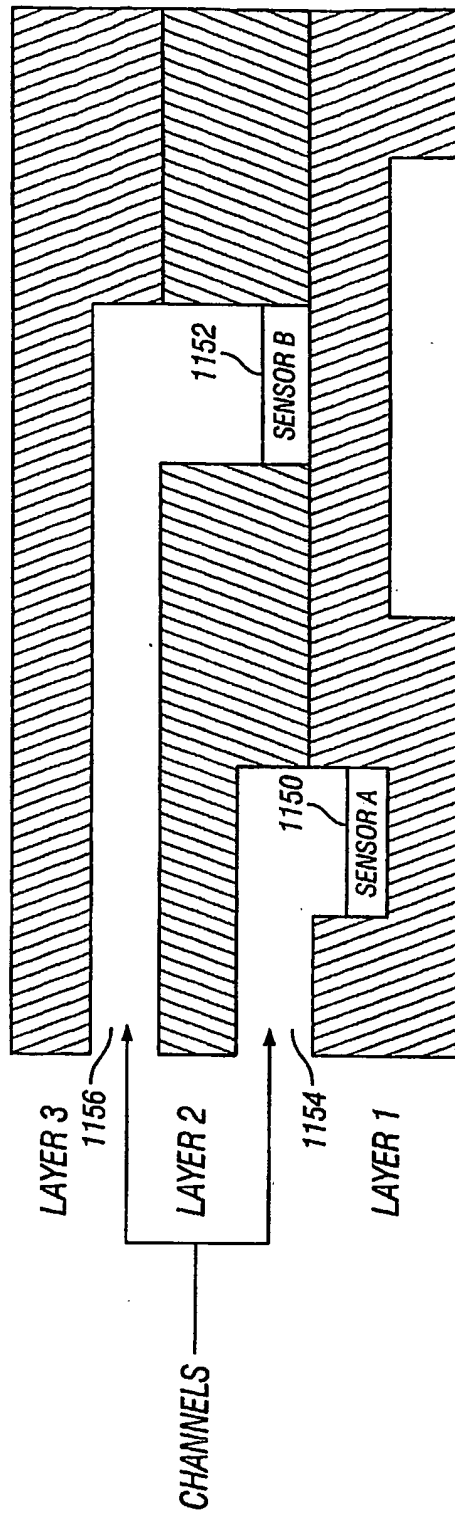

FIG. 116

63/63

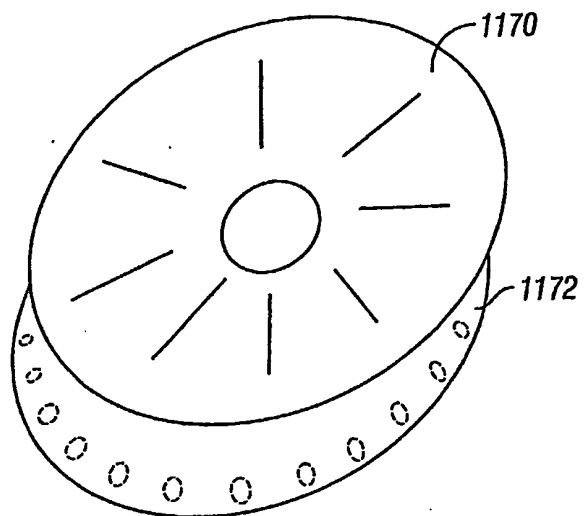

FIG. 117